

# Safe-Lec 2 “V” Contact Bar

## Installation, Operation & Maintenance Manual

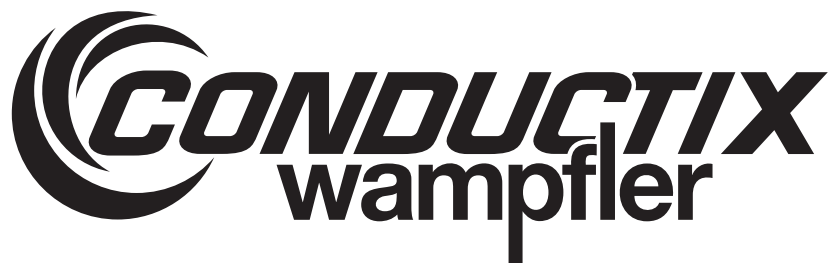
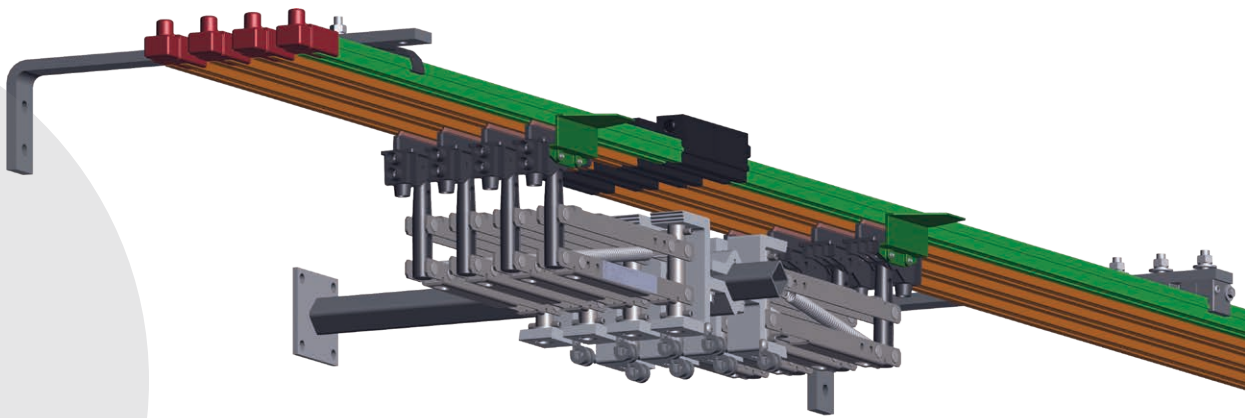

# CONDUCTIX INCORPORATED

The technical data and images which appear in this manual are for informational purposes only. **NO WARRANTIES, EXPRESS OR IMPLIED, INCLUDING WARRANTIES OF MERCHANTABILITY OR FITNESS FOR A PARTICULAR PURPOSE, ARE CREATED BY THE DESCRIPTIONS AND DEPICTIONS OF THE PRODUCTS SHOWN IN THIS MANUAL.** Conductix Inc. makes no warranty (and assumes no liability) as to function of equipment or operation of systems built according to customer design or of the ability of any of its products to interface, operate or function with any portions of customer systems not provided by Conductix Inc.

Seller agrees to repair or exchange the goods sold hereunder necessitated by reason of defective workmanship and material discovered and reported to Seller within one year after shipment of such goods to Buyer.

Except where the nature of the defect is such that it is appropriate, in Seller's judgment, to effect repairs on site, Seller's obligation hereunder to remedy defects shall be limited to repairing or replacing (at Seller's option) FOB point of original shipment by Seller, any part returned to Seller at the risk and cost of Buyer. Defective parts replaced by Seller shall become the property of Seller.

Seller shall only be obligated to make such repair or replacement if the goods have been used by Buyer only in service recommended by Seller and altered only as authorized by Seller. Seller is not responsible for defects which arise from improper installation, neglect, or improper use or from normal wear and tear.

Additionally, Seller's obligation shall be limited by the manufacturer's warranty (and is not further warranted by Seller) for all parts procured from others according to published data, specifications or performance information not designed by or for Seller.

Seller further agrees to replace or at Seller's option to provide a refund of the sales price of any goods that do not conform to applicable specifications or which differ from that agreed to be supplied which non-conformity is discovered and forthwith reported to Seller within thirty (30) days after shipment to the Buyer. Seller's obligation to replace or refund the purchase price for non-conforming goods shall arise once Buyer returns such goods FOB point of original shipment by Seller at the risk and cost of Buyer. Goods replaced by Seller shall become the property of Seller.

There is no guarantee or warranty as to anything made or sold by Seller, or any services performed, except as to title and freedom from encumbrances and, except as herein expressly stated and particularly, and without limiting the foregoing, there is no guarantee or warranty, express or implied, of merchantability or of fitness for any particular purpose or against claim of infringement or the like.

Seller makes no warranty (and assumes no liability) as to function of equipment or operation of systems built to Buyer's design or of the ability of any goods to interface, operate or function with any portions of Buyer's system not provided by Seller.

Seller's liability on any claim, whether in contract, tort (including negligence), or otherwise, for any loss or damage arising out of, connected with, or resulting from the manufacture, sale, delivery, resale, repair, replacement or use of any products or services shall in no case exceed the price paid for the product or services or any part thereof which give rise to the claim. In no event shall Seller be liable for consequential, special, incidental or other damages, nor shall Seller be liable in respect of personal injury or damage to property not the subject matter hereof unless attributable to gross misconduct of Seller, which shall mean an act or omission by Seller demonstrating reckless disregard of the foreseeable consequences thereof.

Seller is not responsible for incorrect choice of models or where products are used in excess of their rated and recommended capacities and design functions or under abnormal conditions. Seller assumes no liability for loss of time, damage or injuries to property or persons resulting from the use of Seller's products. Buyer shall hold Seller harmless from all liability, claims, suits and expenses in connection with loss or damage resulting from operation of products or utilization of services, respectively, of Seller and shall defend any suit or action which might arise there from in Buyer's name - provided that Seller shall have the right to elect to defend any such suit or action for the account of Buyer. The foregoing shall be the exclusive remedies of the Buyer and all persons and entities claiming through the Buyer.

## CONDUCTIX-WAMPFLER FIELD SERVICE

### Need Field Service for our products? We Can Handle It!

Ask us for a quote on expert system installations, inspections, preventative maintenance, and repairs/retrofits.

As the world's largest single source manufacturer of mobile electrification products, Conductix-Wampfler has the unique ability to offer a degree of service not found anywhere else. Conductix-Wampfler's team of highly qualified service technicians and engineers have years of experience servicing our complete line of products.

We can provide:

- **Annual Service contracts**
- **Installation**
- **Commissioning**
- **Installation supervision** to ensure your installers avoid common mistakes.
- **Troubleshooting** to get you up and running.
- **Pre-planned inspections** to complement your preventive maintenance program.

Call 1-800-521-4888 for further details.



# TABLE OF CONTENTS

<b>SECTION 1 - SAFETY</b>	<b>7-9</b>
1.0 Safety Information Responsibility	7
1.1 Safety Messages	7
1.2 Limitation of Liability	7
1.3 Personnel Requirements-Qualifications	8
1.4 Personnel Requirements-Unauthorized Personnel	8
1.5 Personnel Requirements - Training	9
1.6 Personnel Protective Equipment	9
<b>SECTION 2 - PRODUCT DISPOSAL</b>	<b>10</b>
2.0 Product Disposal & Recycling	10
<b>SECTION 3 - OVERVIEW</b>	<b>11-13</b>
3.0 Conductor System Nomenclature	11
3.1 Typical 3-Phase system Overview	11
3.2 Environmental Considerations	12
3.3 Installation Tools	13
<b>SECTION 4 - GENERAL ASSEMBLY INSTRUCTIONS</b>	<b>14-15</b>
4.0 Installation Overview	14
4.1 Phase 1 - Identify and Organize the Materials	14
4.2 Phase 2 - Install Brackets Along the Runway	14
4.3 Phase 3 - Assemble components as much as possible on ground	14
4.4 Phase 4 - Install Hangers and Conductors Along the Runway	14-15
4.5 Phase 5 - Collector Positioning	15
<b>SECTION 5 - SUPPORT BRACKETS</b>	<b>16</b>
5.0 Support Bracket Installation	16
5.1 Advantage of Factory Made Brackets	16
<b>SECTION 6 - CONDUCTOR HANGERS</b>	<b>17-18</b>
6.0 Four Bar Conductor Hanger Mounting	17
6.1 Tools Needed	17
6.2 Mounting Instructions	17
6.3 Installing Conductors Into Hanger	18
<b>SECTION 7 - ANCHOR HANGER SUPPORT ASSEMBLY</b>	<b>19</b>
7.0 Tools Needed	19
7.1 Anchor Hanger Support Installation	19
<b>SECTION 8 - BOLTED STEEL/COPPER JOINT ASSEMBLY</b>	<b>20</b>
8.0 Tools Needed	20
8.1 Bolted Steel/Copper Joint Installation	20
<b>SECTION 9 - BOLTED ALUMINUM JOINT ASSEMBLY</b>	<b>21</b>
9.0 Tools Needed	21
9.1 Bolted Aluminum Joint Installation	21
<b>SECTION 10 - JOINT COVER ASSEMBLY</b>	<b>22</b>
10.0 Install Joint Cover onto Bolted Assemblies	22

# TABLE OF CONTENTS

<b>SECTION 11 - END CAP ONTO CONDUCTOR BAR ASSEMBLY</b>	<b>23-24</b>
11.0 Galvanized Steel and Copper Conductor Bar Installation	23
11.1 Tools Needed	23
11.2 Installation	23
11.3 Aluminum/Stainless Steel Conductor Bar Installation	24
11.4 Tools Needed	24
11.5 Installation	24
<b>SECTION 12 - EXPANSION SECTION ASSEMBLY</b>	<b>25-26</b>
12.0 Allowable Length and Distance	25
12.1 Expansion Section Installation	26
<b>SECTION 13 - END POWERFEED ASSEMBLY</b>	<b>27</b>
13.0 Tools Needed	27
13.1 End Powerfeed Installation	27
<b>SECTION 14 - LOW AMP JOINT POWERFEED ASSEMBLY</b>	<b>28-29</b>
14.0 Tools Needed	28
14.1 Low Amp Joint Powerfeed Installation	28
14.2 Installation up to and Including 250 Amps	29
<b>SECTION 15 - POWERFEED AND COVER ASSEMBLY</b>	<b>30</b>
15.0 Installation Over 250 up to 400 Amps	30
<b>SECTION 16 - TERMINAL GUIDELINES CHART</b>	<b>31</b>
16.0 Terminal Guidelines	31
<b>SECTION 17 - 100 AMP COLLECTOR MOUNTING DETAILS</b>	<b>32</b>
17.0 XA-SL2C-100S-1M Single Collector	32
17.1 XA-SL2C-100T-1M Tandem Collector	32
17.2 Tools Needed	32
17.3 Installation	32
<b>SECTION 18 - 200 AMP COLLECTOR MOUNTING DETAILS</b>	<b>33</b>
18.0 Ground Flag Installation	33
<b>SECTION 19 - CUSTOMER SUPPLIED CABLE INSTALLATION</b>	<b>34</b>
19.0 Installation	34
<b>SECTION 20 - TRANSFER CAP ASSEMBLY</b>	<b>35-36</b>
20.0 Tools Needed	35
20.1 Transfer Cap Installation	35
20.2 Transfer Cap Mounting Details	36
<b>SECTION 21 - ASSEMBLY OF ISOLATION SPLICE ASSEMBLIES</b>	<b>37</b>
21.0 Tools Needed	37
21.1 Installation	37
<b>SECTION 22 - SYSTEM MAINTENANCE AND INSTALLATION NOTES</b>	<b>38</b>
22.0 Maintenance Notes	38
22.1 Installation Notes	38

# TABLE OF CONTENTS

<b>SECTION 23 - COLLECTOR CONTACT SHOE AND SHOE HOLDER</b>	<b>39</b>
23.0 Tools Needed	39
23.1 Replacement Instructions	39
<b>SECTION 24 - PICKUP GUIDES</b>	<b>40-42</b>
24.0 Overview	40
24.1 Dimensions	41
24.2 Collector Spacing for Installations with Pickup Guides	42
24.3 Hanger Clamp Spacing for Installations with Pickup Guide	42
23.4 Assembly for 1,2,3 & 4-way Pickup Guide	43
<b>SECTION 25 - HANGER CENTERS DIAGRAM</b>	<b>44</b>
<b>SECTION 26 - CONDUCTOR BAR DE-RATING CHART</b>	<b>45</b>
<b>CONTACT INFORMATION</b>	<b>46</b>

# SECTION 1 - SAFETY

## 1.0 Safety Information Responsibility

- 1.0.1 All owner, operator, and maintenance personnel must read and understand all manuals associated with this product before installation, operation, or maintenance.
- 1.0.2 The manual provides information on the recommended installation, operation, and maintenance of this product. Failure to read and follow the information provided could cause harm to yourself or others and/or cause product damage. No one should install, operate, or attempt maintenance of this product prior to familiarizing themselves with the information in this manual.

## 1.1 Safety Messages

The following safety messages are used in this manual to alert you to specific and important safety related information.

### CAUTION

**CAUTION** indicates unsafe actions or situations that have the potential to cause injury, and/or minor equipment or property damage.

### DANGER

**DANGER** indicates hazards that have the potential to cause severe personal injury or death.

### WARNING

**WARNING** indicates unsafe actions or situations that have the potential to cause severe injury, death, and/or major equipment or property damage.

## NOTE

**NOTE** is used to alert you to installation, operation, programming, or maintenance information that is important, but not hazard related.

## 1.2 Limitation of Liability

- 1.2.1 All data and information in this mounting instructions have been compiled in compliance with the applicable standards and regulations, best practice and our many years of experience and knowledge.
- 1.2.2 The manufacturer accepts no liability for damages resulting from:
- Failure to comply with this document
  - Improper use
  - Use by untrained personnel
  - Unauthorized modifications
  - Technical changes
  - Use of unauthorized replacement parts and accessories
  - The actual scope of delivery may differ from the explanations and descriptions provided here if the model in question is a special one, if additional equipped has been ordered or due to recent technical changes.
- 1.2.3 The obligations agreed upon in the delivery agreement and our General Terms and Conditions of business apply, as do the delivery conditions of the manufacturer and the legal regulations applicable at the time the contract was concluded.
- 1.2.4 All products are subject to technical modifications in the context of improvement of function and further development.

## SECTION 1 - SAFETY

### 1.3. Personnel Requirements-Qualifications

#### **WARNING**

Inadequately trained persons are at risk of injury!

Improper use can result in serious personal injury or material damage. All activities must only be performed by qualified personnel.

1.3.1 Only persons who can be expected to perform their work reliably are acceptable personnel. People whose reactions are impaired by drugs, alcohol or medications, for example, are not authorized.

1.3.2 When selecting personnel, follow all age- and occupation-specific guidelines applicable at the location of use.

1.3.3 The following qualifications are specified in the operating instructions for certain fields of activity.

#### 1.3.4 Trained personnel and operators

- Will have participated in a training session, given by the owner, on the tasks assigned to them and the potential hazards in case of improper conduct.
- The owner of the machine or system must document that the appropriate training has taken place.

#### 1.3.5 Specialist personnel

- Will consist of persons capable of performing assigned tasks and independently identifying and avoiding potential hazards based on their specialist training, knowledge and experience as well as their knowledge of the applicable regulations. Persons are deemed to be technically qualified if they have successfully completed training as a master electrician, apprentice electrician, electrical engineer or electrical technician. Persons are also considered technically qualified if they have been employed in an appropriate capacity for several years, receiving theoretical and practical training in that line, and their knowledge and skills have been tested by a specialist in the appropriate field of training.
- The machine or system owner must document that the appropriate certificates or other proofs of qualification have been or are being provided.

### 1.4 Personnel Requirements-Unauthorized Personnel

#### **WARNING**

Danger due to unauthorized personnel!

Unauthorized persons who do not meet the requirements described here are not acquainted with the dangers in the working area. Keep unauthorized personnel away from the working area. In case of doubt, address the person and direct them away from the working area. Stop working, as long as unauthorized persons are in the working area.



# SECTION 1 - SAFETY

## 1.5 Personnel Requirements-Training

1.5.1 Before commissioning the equipment, personnel must be trained by the owner. Log the implementation of training for better traceability.

Example of a training log:

Date	Name	Training Type	Training Instructor	Signature
11/5/2019	John Doe	First safety training for personnel	Dave Miller	

## 1.6 Personal Protective Equipment

1.6.1 For every task, always use:

**Safety helmet:** For protection against falling or flying parts and materials.

**Protective gloves:** For the protection of hands against friction, scrapes, puncture or deeper wounds, as well as against contact with hot surfaces.

**Protective work clothing:** Primarily for protection against entrapment by moving machine parts. Work clothing must be close fitting with a low resistance to tearing; it must have close-fitting sleeves and no protruding parts.

**Protective footwear:** For protection against heavy falling parts and slipping on slippery floors. For special tasks, specific protective equipment is required when executing particular tasks:

**Safety eye wear:** For eye protection against harmful influences such as strong light, chemicals, dust, splinters or weather effects.

**Hearing protection:** For protection against loud noises and to prevent acoustic trauma.

**Breathing mask (FFP-3 - according to country-specific requirements):** For protection against materials, particles, and organisms. In this case, for protection against the dust produced by the abrasion of carbon brushes and the PVC insulation of the conductor rail.

## SECTION 2 - PRODUCT DISPOSAL

### 2.0 Product Disposal and Recycling

2.0.1 Once the product has reached its end of life it must be disassembled and disposed of in accordance with local and regional environmental requirements.

2.0.2 In the absence of a return and disposal agreement, disassembled components must be recycled as follows:

- All metallic parts must be sorted and recycled by material type
- All plastic components must be sorted and recycled by material type
- All other components are to be disposed of in accordance with their material composition. Take care with items identified as Substances of Concern.

2.0.3 Local authorities or special disposal companies can provide information about environmentally appropriate disposal.

# SECTION 3 - OVERVIEW

## 3.0 Conductor System Nomenclature

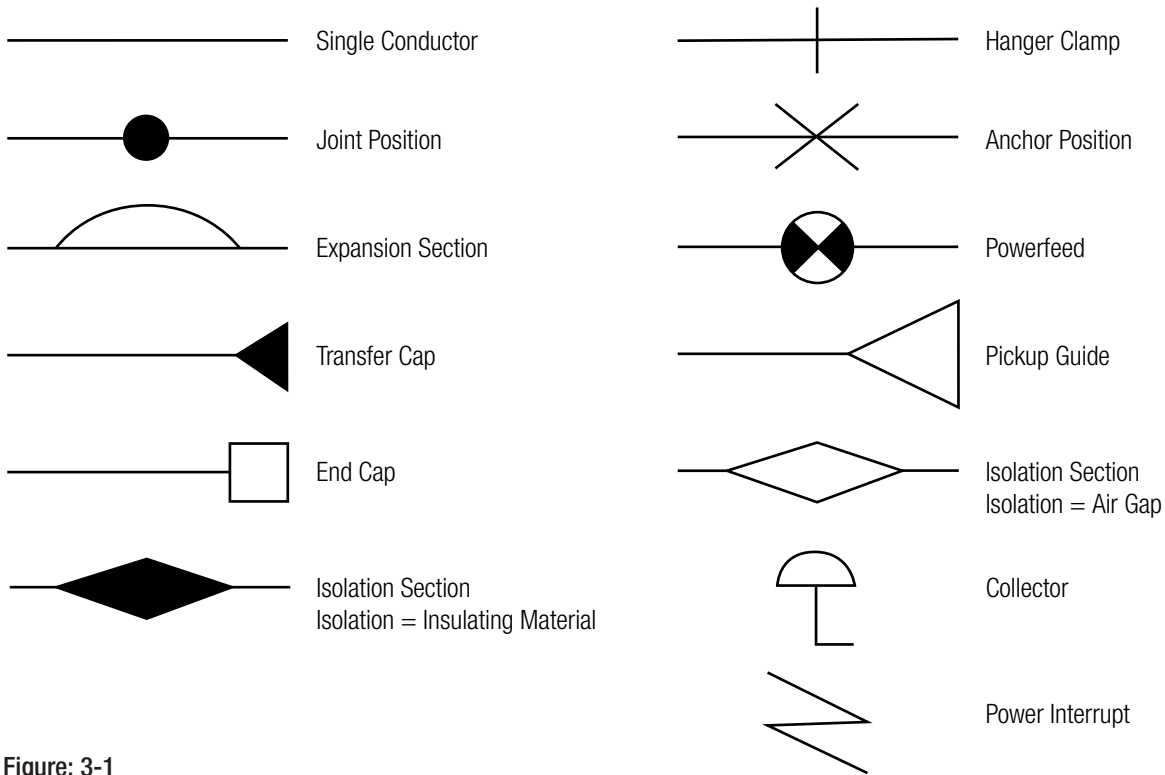
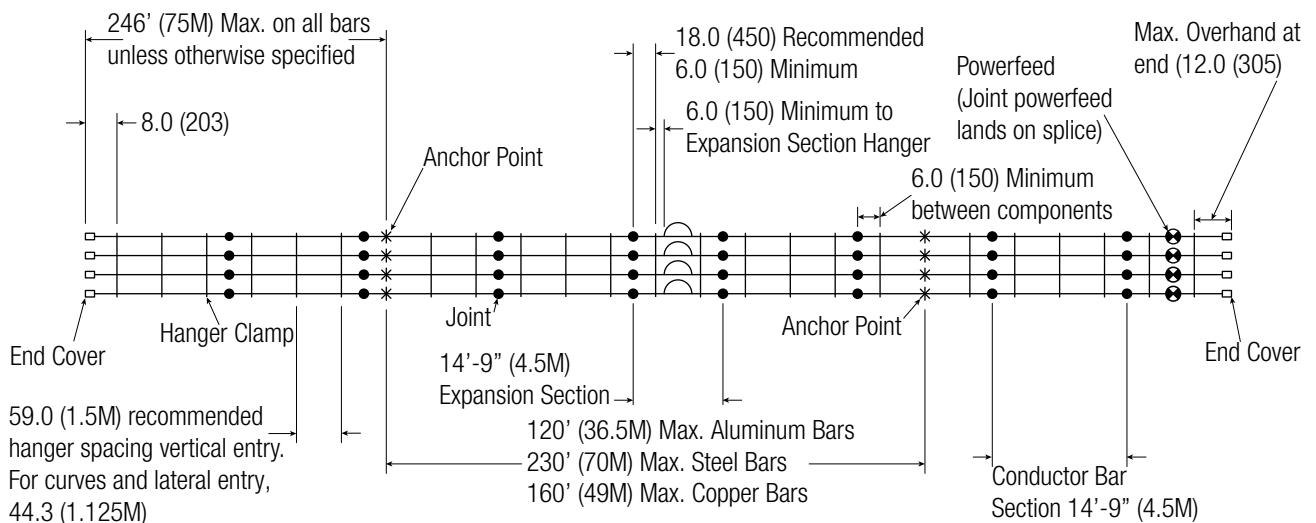

Figure: 3-1

## 3.1 Typical 3-Phase System Overview



**NOTE:** Maximum length without expansions is 492' (150M), use anchor clamp at center

Figure: 3-2

## SECTION 3 - OVERVIEW

### 3.2 Environmental Considerations

- Standard Cover (PVC) is suitable up to 160°F.
- Medium Heat Cover (Polycarbonate) is suitable up to 250°F.

**NOTE:** The following acidic or corrosive environments require the use of stainless steel hangers:

- Hydrochloric Acid
- Hydrofluoric Acid
- Sodium Hydrochloride
- Ammonium Chloride
- Chlorine Bleach
- Chloride Ions
- Fluoride Ions

### **WARNING**

- Do not use standard (black) or medium heat (red) hangers in the above environment

## SECTION 3 - OVERVIEW

### 3.3 Installation Tools

3.3.1 Organize the following tools before doing installation

- Man lift or platform lift for access to the installation location *(if needed)*
- Sharp knife - to cut powerfeed grommets
- Steel rule or tape measure - to position collectors during installation
- Wire/cable stripper
- Cable lug crimping tool
- Cordless drill with socket adapter *(1/4" or 3/8" drive)*
- Hex Wrenches
  - > 4mm - for securing feed cable to 100 Amp collector and replacing shoe
  - > 5mm - for securing feed cable to 200 Amp collector and replacing shoe
- Deep sockets for Cordless Drill
  - > 8mm - for anchor cross bolts
  - > 10mm - for splices, isolation sections, and powerfeeds
  - > 13mm - for mounting hangers, anchors, and transfer caps
  - > 16mm - for mounting collector assemblies
- Torque wrench for sockets listed above
- Open/box end wrenches *(use ratcheting box-end wrenches if you have them)*
  - > 8mm
  - > 10mm
  - > 13mm
- Hacksaw
- Flat file and/or rat tail file to remove burrs on field cut conductors
- Pliers
- #1 Phillips Head Screwdriver

## SECTION 4 - GENERAL ASSEMBLY INSTRUCTIONS

### **WARNING**

- Always lockout-tagout all electrical power before starting work

#### 4.0 Installation Overview

4.0.1 This manual provides detailed instructions in the general order of system installation. Consult Heater Wire Installation Manual for systems provided with anti-condensation heater wire. System installation consists of five phases:

#### 4.1 Phase 1 - Identify and Organize the Materials

- 4.1.1 Check the pack list against the items received. Parts are labelled for your convenience. Review your specific installation layout drawing (*if provided*) or the typical layout diagram seen previously in this manual to become familiar with component location on the system. Note where the anchors, expansions, powerfeeds, and other assemblies will be located along the runway. Read through these instructions before starting work.

#### NOTE:

- Make sure to check for smaller components that may be located inside the false bottom of the packaging.

#### 4.2. Phase 2 - Install Brackets Along the Runway

- 4.2.1 Install brackets per diagram included at the start of this manual. Keep them as level and evenly spaced as possible. You may install the hangers on the brackets before or after they are mounted along the runway.

#### 4.3 Phase 3 - Assemble components as much as possible on the ground

- 4.3.1 It is faster, safer, and more convenient to assemble as much as possible on the ground should you drop something. Conductor Bar and Expansion Sections will come from the factory with one splice pre-installed.
1. Install end caps on the end conductors, keeping these separated from the main runway conductors.
  2. Install isolation splices (*if included*) on the ends of the conductors in accordance with the installation layout drawing and the instructions (*See Table of Contents*).
  3. Install transfer caps on the conductor ends (*if included*).

#### 4.4 Phase 4 - Install Hangers and Conductors Along the Runway

- 4.4.1 The installation will most likely be accomplished from a lift or work platform.
1. Ensure the power is locked out-tagged out.
  2. Install the hangers per instructions (*See Table of Contents*).
  3. Roll adjacent conductors in the hangers as shown in Section 6.2. Conductix-Wampfler recommends the first accessible conductor being the ground conductor.
  4. Move down the runway, install the next inboard conductor and join it to the corresponding conductor installed in Step 3. Install the splice cover. Keep the splice assemblies 6-12 inches from the hanger brackets to allow for conductor movement and expansion. Repeat for the remaining phases and ground conductors.
  5. When you get to where the expansion assemblies are to be installed, refer to those instructions (*See Table of Contents*). Be sure to divide the total expansion gap distance (from chart) between the two air gap locations in the expansion assembly.
  6. Proceed with system installation, ensuring anchors are positioned the correct distance from the expansions and that they are tightened to the correct torque.
  7. If the conductor must be cut to a specific length, ensure that the cut end is properly de-burred. The conductor cover is always shorter than the bar length, the proper cover length is 66 mm (2.60") shorter than the bar length, (33 mm / 1.30" on each end).

## SECTION 4 - GENERAL ASSEMBLY INSTRUCTIONS

8. When you run the feed cable to the powerfeed assembly, ensure the cables have sufficient free length and are flexible enough to enable movement of the conductor due to expansion. Locating the powerfeed as close as possible to the anchors minimizes this concern. Do not support the weight of the feed cables with the conductors.
9. Install powerfeeds on conductor bars per layout and the instructions (*See Table of Contents*).

### 4.5 Phase 5 - Collector Positioning

4.5.1 Properly position and align Collector Assemblies to ensure safe, reliable operation.

- For 100 Amp and 200 Amp collectors, the center line of the conductor mounting post must be 102 mm (4.0") below the contact surface of the conductor bars. When installed, the collector arms should be parallel with the contact surface of the bar.
- Slide the collectors on the mounting staff. Ensure the mounting base of each collector is centered below the corresponding conductor. Ensure the collectors are evenly spaced. Tighten hardware to specifications and connect the power supply cable to the collector per diagram (*See Table of Contents*).

#### NOTE:

- Follow all lockout/tagout procedures.
- Keep accessories at least 6" from hanger brackets.
- Follow all torque specifications.
- Allow for movement of accessories due to expansion.
- Connect only flexible power cables to powerfeed assemblies.
- Keep collectors straight, level, and aligned with conductors.

# SECTION 5 - SUPPORT BRACKETS

## 5.0 Support Bracket Installation

5.0.1 Locate and secure support brackets at the recommended spacing. (See Figure 5-1).

### NOTE:

- Locate support brackets at a spacing that is divisible into conductor bar lengths. This will ensure that the joint positions do not interfere with the support brackets.

5.0.2 Observe all alignment tolerances. (See Figure 5-1).

- > Datum height
- > Maximum allowable deviation from datum height + 5.0 mm (+3/16").

## 5.1 Advantage of Factory Made Brackets

5.1.1 Safe-Lec 2 Hanger Brackets come complete with all necessary mounting holes for easy installation of hangers via slide in slots or holes.

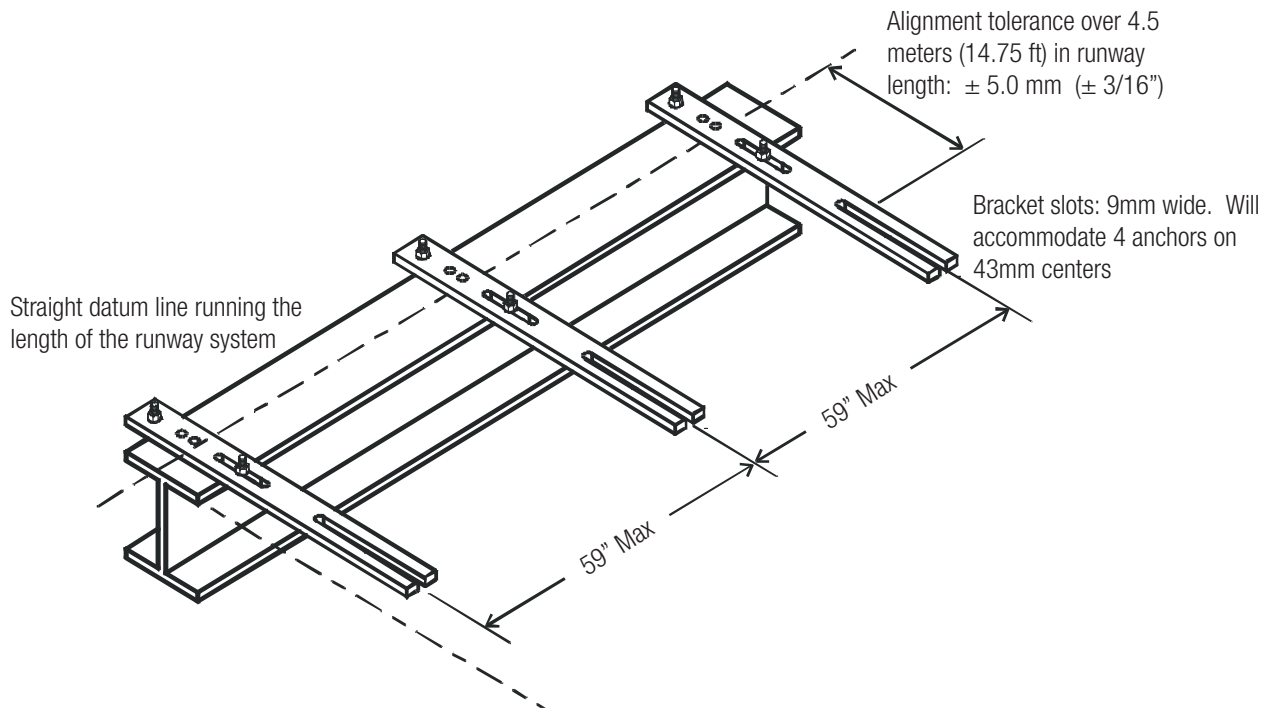

Figure: 5-1



## SECTION 6 - CONDUCTOR HANGERS

### 6.0 Four Bar Conductor Hanger Mounting

#### NOTE:

- For indoor and limited indoor use use part no. XA-310821
- For lateral mount - Consult Factory

### 6.1 Tools Needed

- A/F Wrench  
> 13 mm

### 6.2 Mounting Instructions

1. Remove nut, lock washer, and washer from hanger assembly (the M8 bolt will stay in place inside the molding).
2. Assemble as shown in the diagram, ensuring the correct alignment is observed. (See Figure 6-1).
3. Finger tighten M8 nut.
4. Snap conductor bars into hangers.
5. Tighten M8 nut to Conductix-Wampfler recommended torque of 8 Nm (5-6 ft-lbs.)

#### NOTE:

- This hanger may be used when the bar system is covered and protected from the elements. If the bar system will be directly exposed to rain, snow, ice or other precipitation, a single pole insulated hanger must be used.

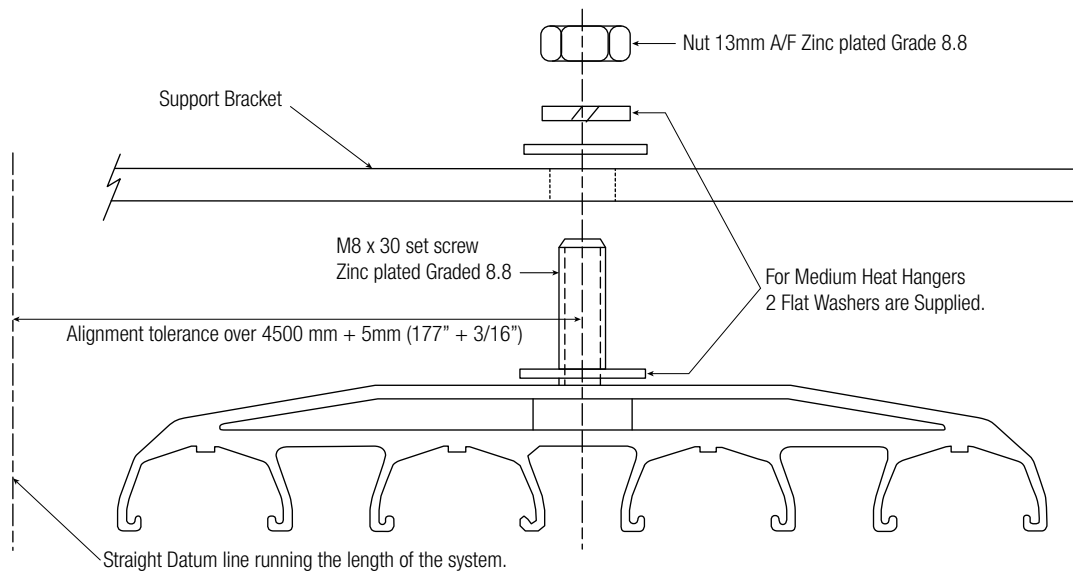

Figure: 6-1

## SECTION 6 - CONDUCTOR HANGERS

### 6.3 Installing Conductors Into Hanger

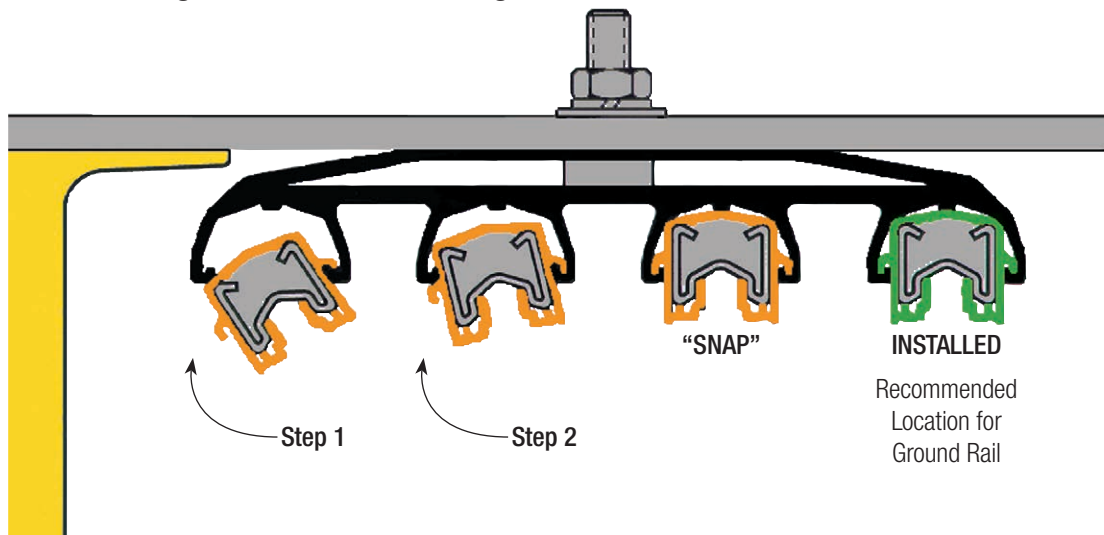

Figure: 6-2

## SECTION 7 - ANCHOR HANGER SUPPORT ASSEMBLY

### NOTE:

- For ease of access to clamping screws, install anchor hanger assemblies as shown below.

### 7.0 Tools Needed

- A/F Open ended wrench  
> 13 mm  
> 8 mm

### 7.1 Anchor Hanger Support Installation

1. Assemble anchor over cover so it is free to slide.
2. Insert anchor hanger into support bracket.
3. Tighten M5 Bolts until anchor stops meet (check anchor is tight on cover).
4. Tighten M8 Bolt to a torque of 8 Nm (5-6 ft. lbs).

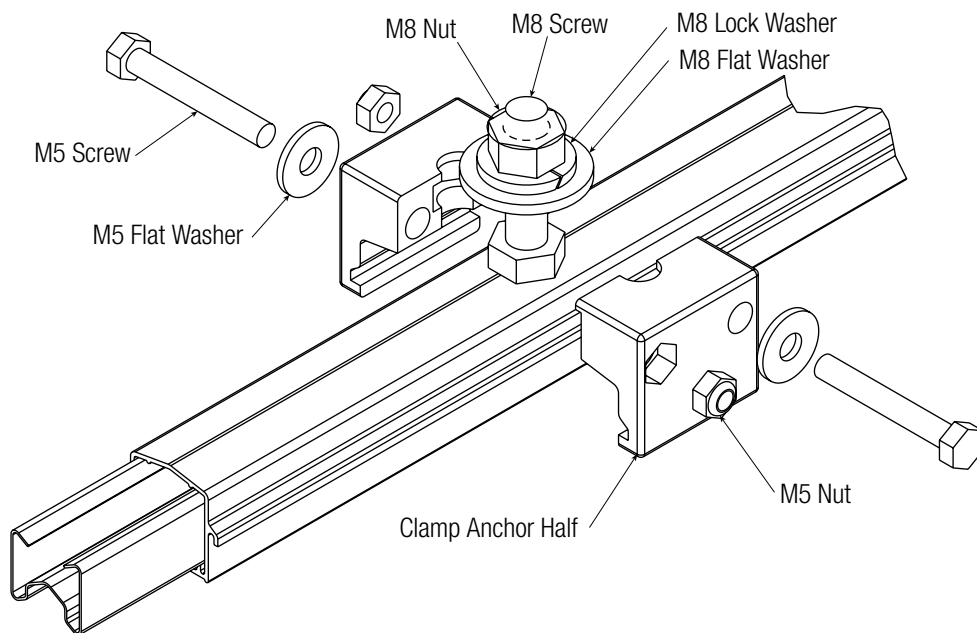

Figure: 7-1

## SECTION 8 - BOLTED STEEL/COPPER JOINT ASSEMBLY

### 8.0 Tools Needed

- A/F open ended wrench  
> 10 mm

### 8.1 Bolted Steel/Copper Joint Installation

1. Fit into joint plate (ensure tab captivates the head on the setscrew).
2. Slide bolt and joint plate into conductor bar ends.
3. Place joint over bolt, making sure alignment mark is in line with end faces of conductor bar.
4. Fit washer and nut onto bolt in the order shown.
5. Tighten nut to recommended torque of 8 Nm (5-6 ft. lbs).
6. Check that both faces of the conductor bar are touching each other and there is no gap exceeding 0.5mm (0.02") at the faces.

### NOTE:

- If the conductor was field cut, file off all burrs on conductor ends before assembling splices.

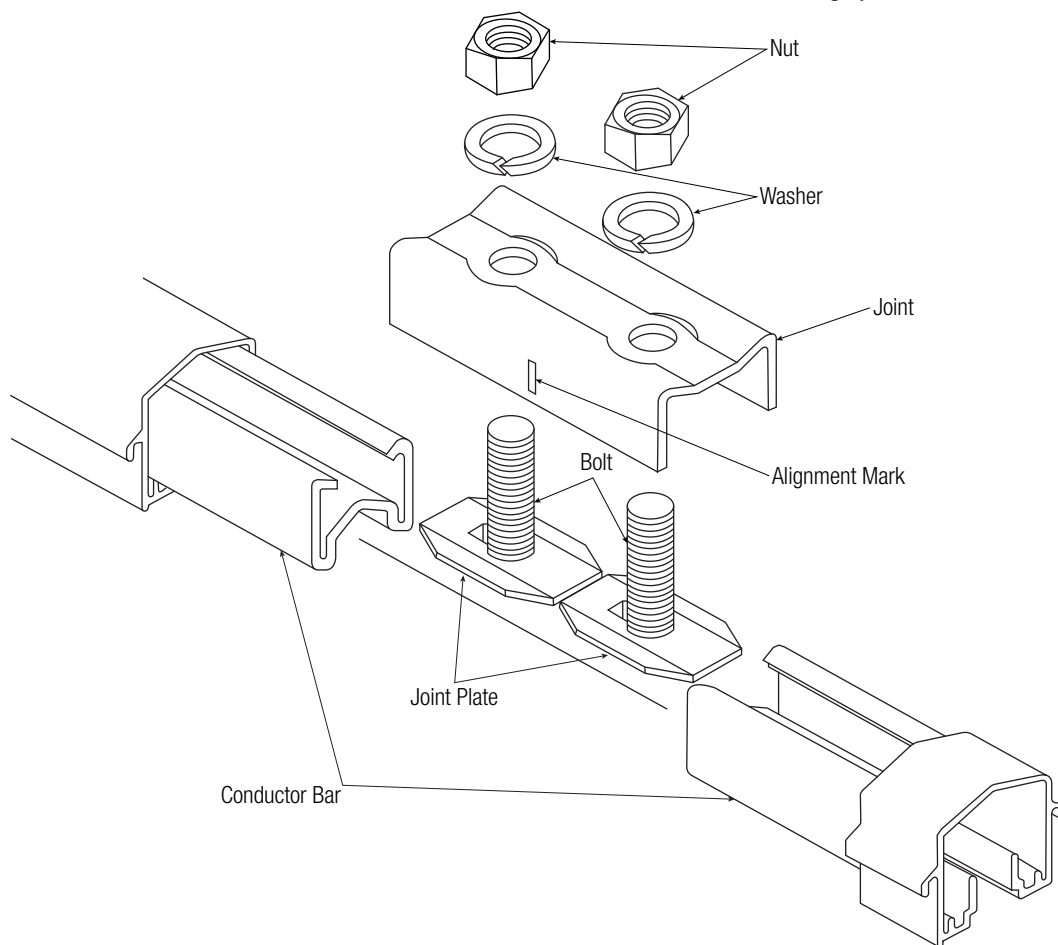

Figure: 8-1

## SECTION 9 - BOLTED ALUMINUM JOINT ASSEMBLY

### 9.0 Tools Needed

- A/F open ended wrench  
> 10 mm
- Electrical Joint Compound (part no. XA-15629)

### 9.1 Bolted Aluminum Joint Installation

1. Apply electrical joint compound to all mating surfaces.
2. Slide bolt into conductor bar ends.
3. Place joint plate over bolts.
4. Fit washer and nut as shown.
5. Tighten nut to recommended torque of 8 Nm (5-6 ft. lbs).
6. Check that both faces of the conductor bar are touching each other and there is no gap exceeding 0.5mm (0.02") at the faces.

### NOTE:

- If the conductor was field cut, file off all burrs on conductor ends before assembling splices. Exposed length of bar should be 33mm (1.3") per end.

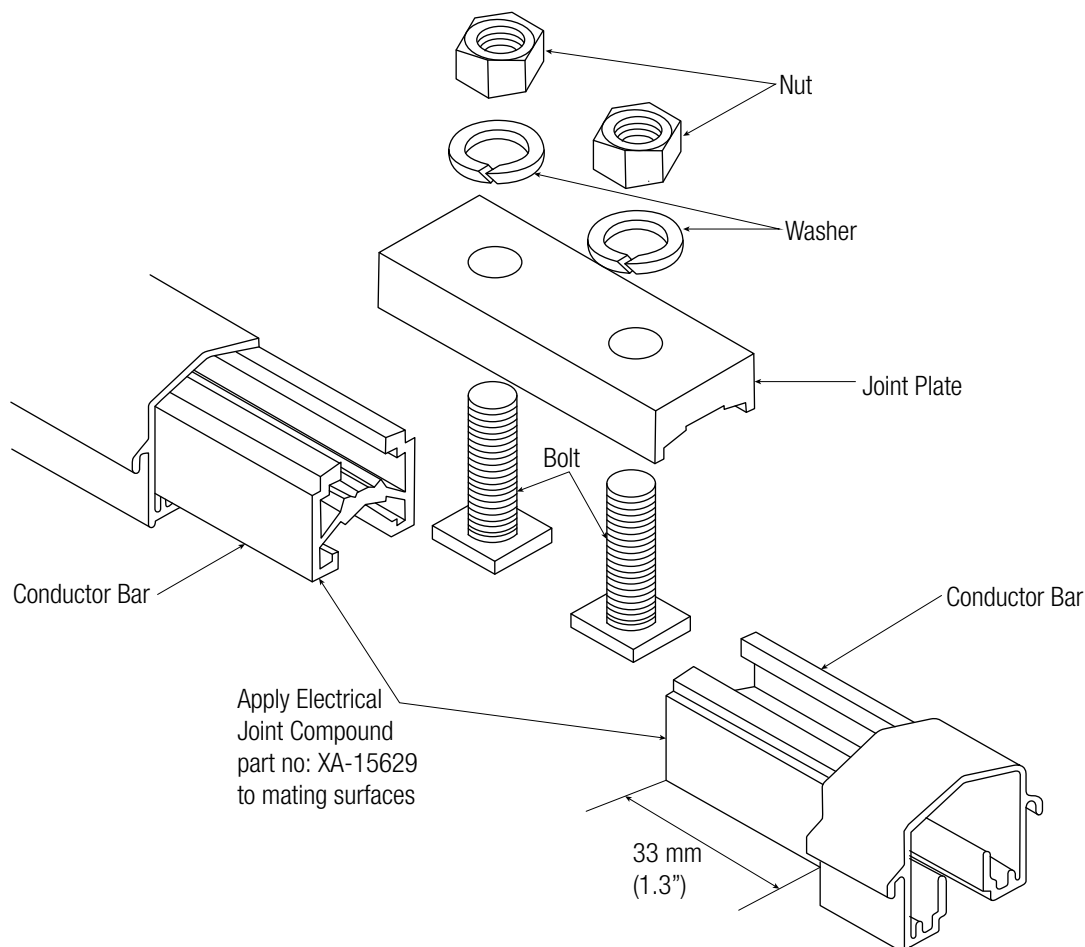

Figure: 9-1

## SECTION 10 - JOINT COVER ASSEMBLY

### 10.0 Install Joint Cover onto Bolted Assemblies

1. Spring legs out in the directions "A-A" as shown (this is to ease the fitting of the joint cover over the conductor bar).
2. Fit the joint cover over the bolted joint. Joint cover MUST NOT be opened up more than 45° on either side during the assembly over the joint. Ensure the "Location Section" sits between the two bolts.
3. Close the flaps in the direction "B". Ensure the flaps "click" home on both sides.

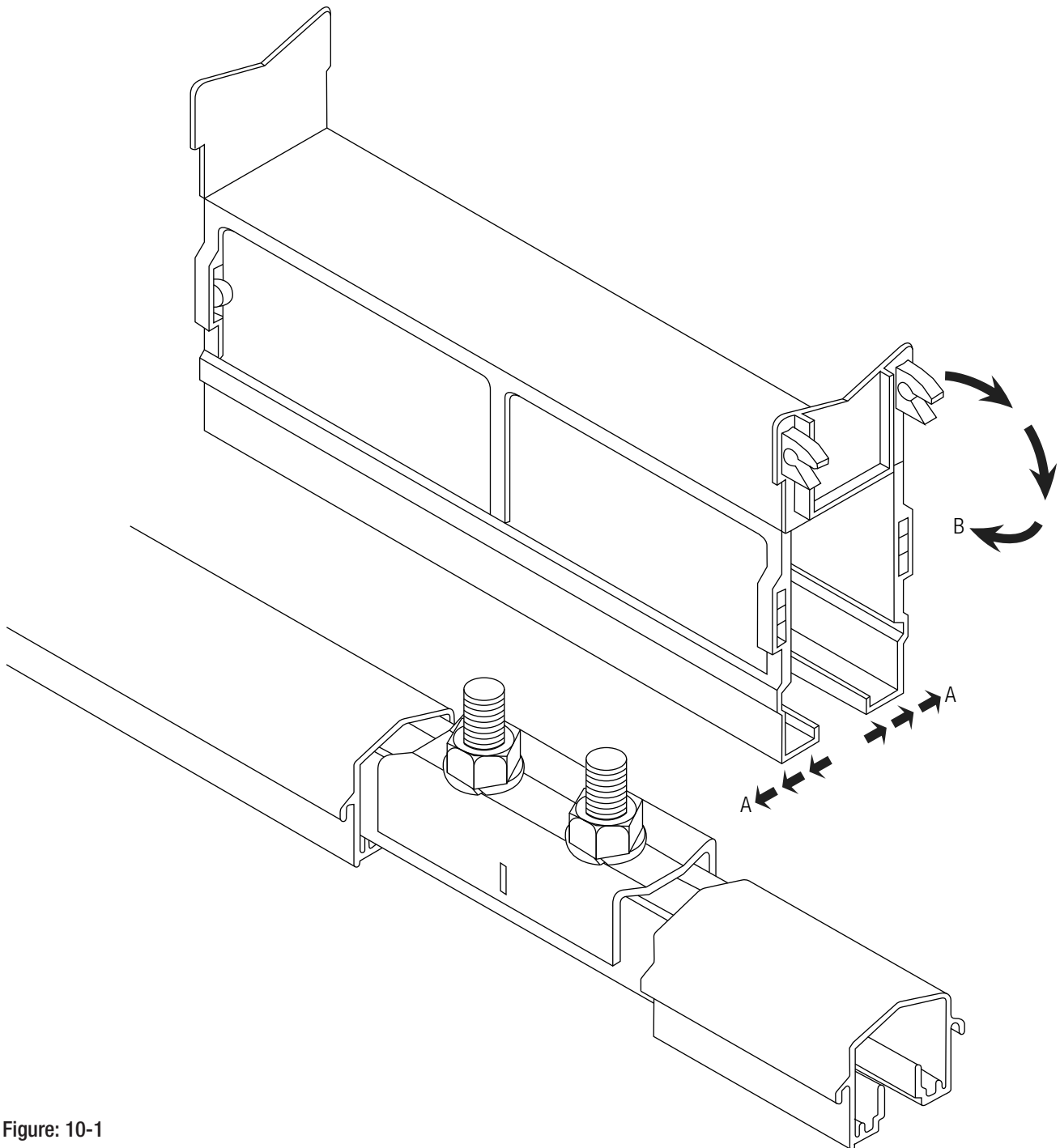

Figure: 10-1

## SECTION 11 - END CAP ONTO CONDUCTOR BAR ASSEMBLY

### 11.0 Galvanized Steel and Copper Conductor Bar Installation

11.0.1 Install end caps onto galvanized steel and copper bars see *Figure 11-1*.

#### 11.1 Tools Needed

- A/F open ended wrench  
> 10 mm

#### 11.2 Installation

1. Fit bolt into joint plate (ensure tab captivates the head on the set screw).
2. Place bolt and joint plate assembly into conductor bar.
3. Place end cover clamp, washer, and nut over bolt and joint plate assemblies (ensure end cover clamp is flush with conductor bar face).
4. Tighten nut to a recommended torque of (40-50 In-lbs) 5-6 Nm.
5. Slide End Cap End Plug into the grooves at the back of the Top Cover.
6. Place Top cover onto bar end making sure that the circular pocket aligns with the square bolt.
7. Align Bottom Cover with Top Cover and End Plug. Apply slow but firm pressure to both Top and Bottom Covers, until all four tabs have snapped securely into place.

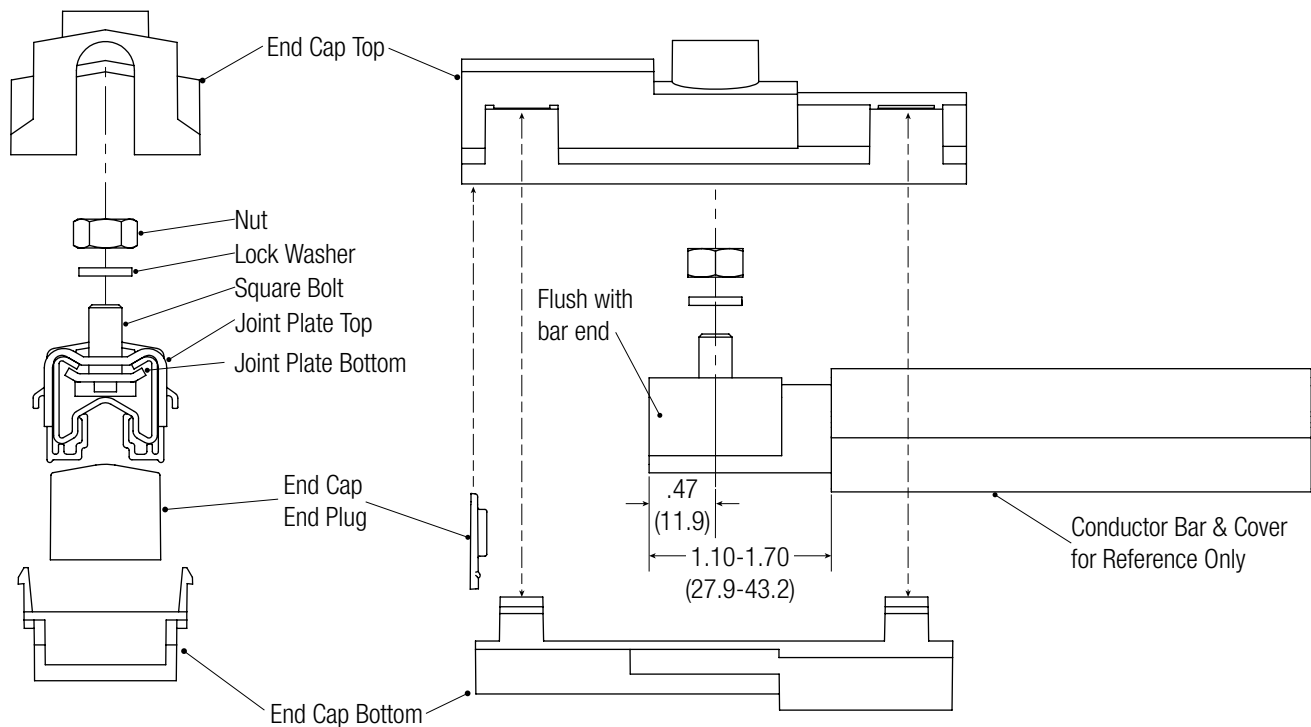

Figure: 11-1

## SECTION 11 - END CAP ONTO CONDUCTOR BAR ASSEMBLY

### 11.3 Aluminum/Stainless Steel Conductor Bar Installation

11.3.1 Install end caps onto aluminum/stainless steel conductor bars.

### 11.4 Tools Needed

- A/F open ended wrench  
> 10 mm

### 11.5 Installation

1. Mark conductor bar top surface 11.9 mm (0.47") from end face.
2. Fit bolt into conductor bar.
3. Ensure center line of setscrew bolt is on the center line marked on the conductor surface.
4. Place nut, lock washer, and flat washer on bolt in the order shown in *Figure 11-2*.
5. Slide End Cap End Plug into the grooves at the back of the Top Cover.
6. Place Top cover onto bar end making sure that the circular pocket aligns with the square bolt.
7. Align Bottom Cover with Top Cover and End Plug. Apply slow but firm pressure to both Top and Bottom Covers, until all four tabs have snapped securely into place.

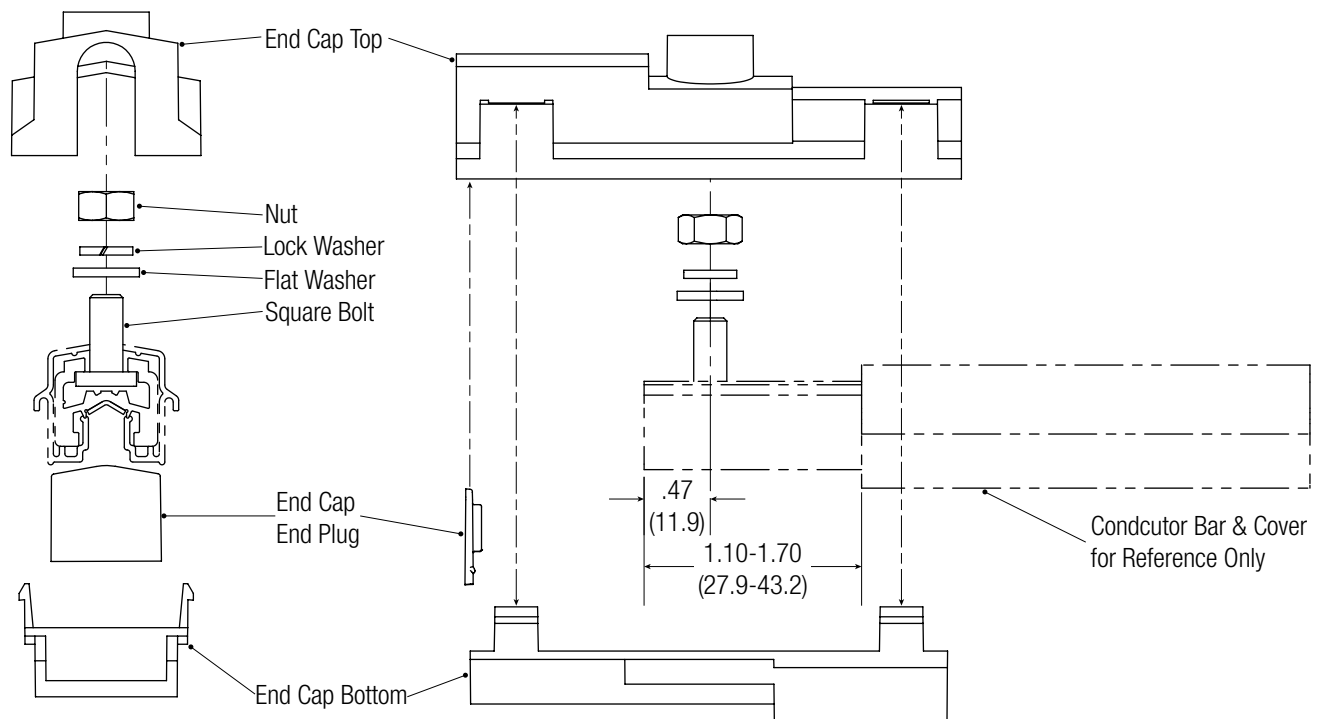

Figure: 11-2



# SECTION 12 - EXPANSION SECTION ASSEMBLY

## 12.0 Allowable Length & Distance

- The maximum allowable conductor system length without an Expansion Section is 150 m (492') - *Assuming a Maximum Temperature Range of 110° F.*
- All conductor systems longer than 492' (149.9 m) must have expansion sections installed. See Image 12-0 for general arrangement of expansions and Table 12-0 for system length and anchor spacing.

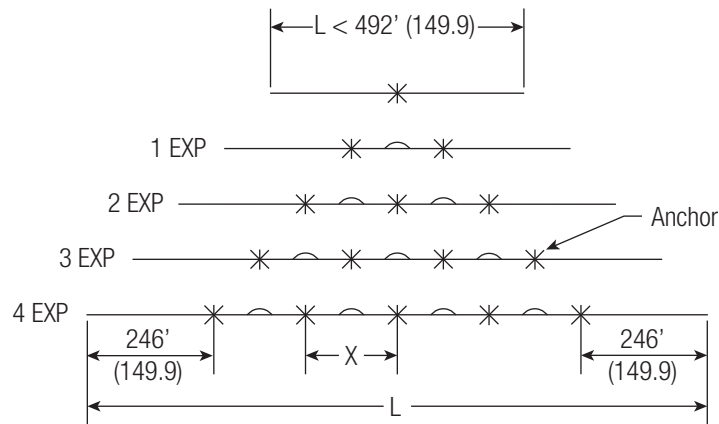

Figure: 12-0

Number of Expansion Units	1			2			3			4			X			
	Galv	Al	Cu	Galv	Al	Cu	Galv	Al	Cu	Galv	Al	Cu	Galv	Al	Cu	
Ambient Temp Max-Min	Maximum System Length, L (ft)												Maximum Length Between Anchors, X (ft)			
ΔT (°F)	30	787	645	698	1083	797	905	1378	950	1111	1673	1103	1318	295	153	206
	50	730	615	659	969	739	826	1207	862	992	1446	985	1159	238	123	167
	70	692	595	632	892	699	772	1092	802	912	1292	906	1051	200	103	140
	90	664	581	612	836	670	733	1009	759	853	1181	848	974	172	89	120
	110	643	570	598	794	648	704	946	727	809	1097	805	915	151	78	106
	130	627	562	586	762	631	681	896	701	775	1031	771	869	135	70	94
	150	614	555	577	735	618	662	857	681	747	978	743	832	122	63	85
	170	603	549	569	713	606	647	824	664	724	935	721	802	111	57	77
	190	594	545	563	695	597	634	797	650	705	899	702	776	102	53	71
210	586	541	558	680	589	623	774	638	689	868	686	755	94	49	66	

Table: 12-0

### NOTE:

- For systems longer than those in the table above, use:  $(L-492)/X$  = number of expansion units.

# SECTION 12 - EXPANSION SECTION ASSEMBLY

## 12.1 Expansion Section Installation

1. Set expansion air gaps when installing assembly to appropriate gap setting for ambient temperature (see Table 22-1). The gap is adjusted by sliding the moving lengths of conductor in or out of the expansion assembly (**BOTH HALVES MUST BE SET EQUAL**). Always allow sufficient time for conductor bars to achieve ambient temperature before setting expansion gap. All expansion assemblies must be set at site, they are not pre-set before leaving the factory. Failure to set this part correctly could result in buckling of conductors.
2. Set anchor clamp and torque on one side, install up to next anchor clamp but DO NOT TIGHTEN. Go back and set expansion to correct gap setting per current ambient temperature. Once gap is set, go to second anchor clamp and tighten.

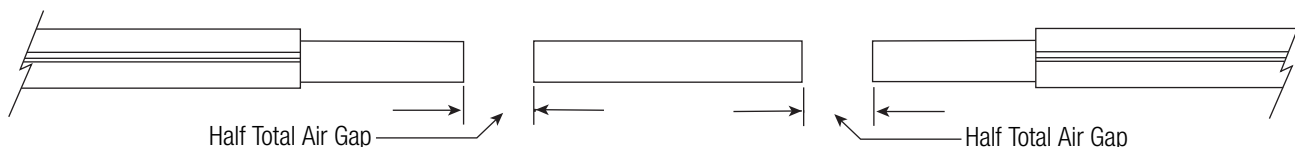

Image: 12-1

		Actual Site Ambient Temperature: °C (°F)																	
		-25° (-13)	-20° (-4)	-15° (5)	-10° (14)	-5° (23)	0° (32)	5° (41)	10° (50)	15° (59)	20° (68)	25° (77)	30° (86)	35° (95)	40° (104)	45° (113)	50° (122)	55° (131)	
Lowest Possible Site Ambient Temperature °C (°F) See Note	25° (77)												50 (1.97)	45 (1.77)	41 (1.61)	36 (1.42)	32 (1.26)	27 (1.06)	23 (0.91)
	20° (68)											50 (1.97)	46 (1.81)	42 (1.65)	38 (1.50)	33 (1.30)	29 (1.14)	25 (0.98)	21 (0.83)
	15° (59)										50 (1.97)	46 (1.81)	42 (1.65)	38 (1.50)	35 (1.38)	31 (1.22)	27 (1.06)	23 (0.91)	19 (0.75)
	10° (50)									50 (1.97)	46 (1.81)	43 (1.69)	39 (1.54)	36 (1.42)	32 (1.26)	29 (1.14)	25 (0.98)	21 (0.83)	18 (0.71)
	5° (41)								50 (1.97)	47 (1.85)	43 (1.69)	40 (1.57)	37 (1.46)	33 (1.30)	30 (1.18)	27 (1.06)	23 (0.91)	20 (0.79)	17 (0.67)
	0° (32)							50 (1.97)	47 (1.85)	44 (1.73)	41 (1.61)	38 (1.50)	34 (1.34)	31 (1.22)	28 (1.10)	25 (0.98)	22 (0.87)	19 (0.75)	16 (0.63)
	-5° (23)						50 (1.97)	47 (1.97)	44 (1.73)	41 (1.61)	38 (1.50)	35 (1.38)	32 (1.26)	29 (1.14)	26 (1.02)	24 (0.94)	21 (0.83)	18 (0.71)	15 (0.59)
	-10° (14)				50 (1.97)	47 (1.85)	44 (1.73)	42 (1.65)	39 (1.54)	36 (1.42)	33 (1.30)	31 (1.22)	28 (1.10)	25 (0.98)	22 (0.87)	19 (0.75)	17 (0.67)	14 (0.55)	
	-15° (5)			50 (1.97)	47 (1.85)	45 (1.77)	42 (1.65)	39 (1.54)	37 (1.46)	34 (1.34)	32 (1.26)	29 (1.14)	26 (1.02)	24 (0.94)	21 (0.83)	18 (0.71)	16 (0.63)	13 (0.51)	
	-20° (-4)		50 (1.97)	48 (1.89)	45 (1.77)	43 (1.69)	40 (1.57)	38 (1.50)	35 (1.38)	33 (1.30)	30 (1.18)	28 (1.10)	25 (0.98)	23 (0.91)	20 (0.79)	18 (0.71)	15 (0.59)	13 (0.51)	
	-25° (-13)	50 (1.97)	48 (1.89)	45 (1.77)	43 (1.69)	40 (1.57)	38 (1.50)	36 (1.42)	33 (1.30)	31 (1.22)	29 (1.14)	26 (1.02)	24 (0.94)	21 (0.83)	19 (0.75)	17 (0.67)	14 (0.55)	12 (0.47)	

Table: 12-1

## SECTION 13 - END POWERFEED ASSEMBLY

### NOTE:

- Installation is for 100 Amp Conductor Bar Only.

### 13.0 Tools Needed

- A/F Wrench  
> 10 mm
- Suitable Sharp Knife
- Cable Stripper
- Cable Crimping Tool
- Suitable Cable Terminal (see list of recommended suppliers and references).

### 13.1 End Powerfeed Installation

1. Cut powerfeed end cap to suit cable diameter.
2. Pass cable through powerfeed end cap.
3. Crimp terminal to cable.
4. Fit bolt into joint plate (wings on tab to face upward).
5. Fit assembly into conductor bar.
6. Fit clamp over joint plate and bolt. Secure with half nut. Tighten half nut to recommended torque value of 10 Nm (7-8 ft.-lbs.).
7. Fit terminal and secure washer and nut.
8. Tighten nut to recommended torque of 8 Nm (5-6 ft.-lbs.).
9. Push powerfeed end cap over assembly (ensure bolt is located in point "A" on powerfeed end cap).

### NOTE:

- Maximum cable size is 25 sq mm PVC 600/1000V stranded copper conductor (#4 AWG Extra Flexible)

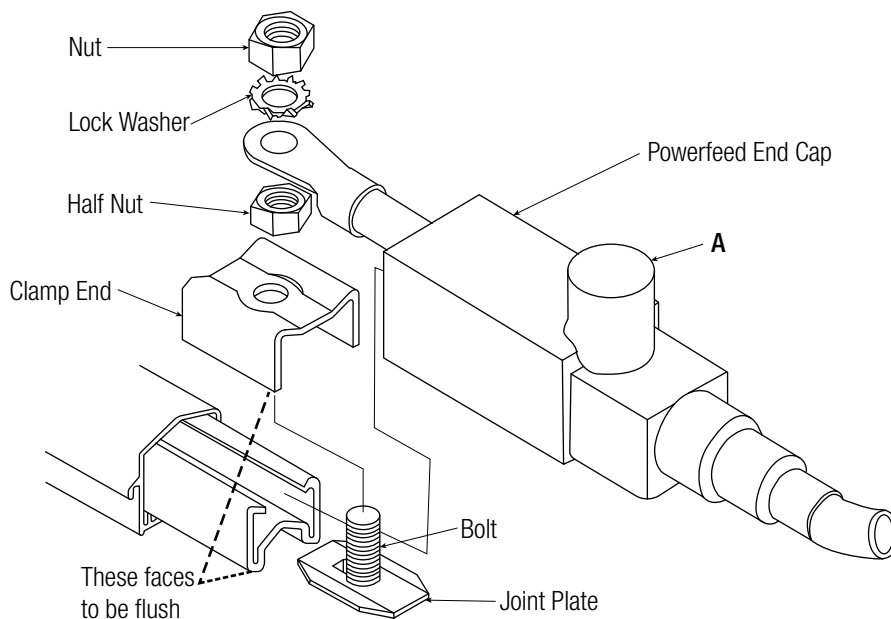

Figure: 13-1

## SECTION 14 - LOW AMP JOINT POWERFEED ASSEMBLY

### NOTE:

- Installation up to 100 Amp.

### 14.0 Tools Needed

- A/F Wrench  
> 10 mm
- Suitable Sharp Knife
- Cable Stripper
- Cable Crimping Tool
- Suitable Cable Terminal (see list of recommended suppliers and references).

### 14.1 Low Amp Joint Powerfeed Installation

1. Remove black plug on powerfeed cap.
2. Assemble joint to conductor bar as described previously.
3. Pass supply cable through grommet.
4. Crimp terminal to supply cable.
5. Secure terminal to joint using washer and nut to tighten nut to a recommended torque of 8 Nm (5-6 ft.-lbs).
6. Fit powerfeed cap over assembly (ensure the cable is threaded carefully through grommet).
7. Once in position close flaps and ensure flaps click home.

### NOTE:

- Joint must not support cable.
- Max. cable size 10sq. mm pvc 600/1000V stranded copper conductor (#8 AWG Extra Flexible).

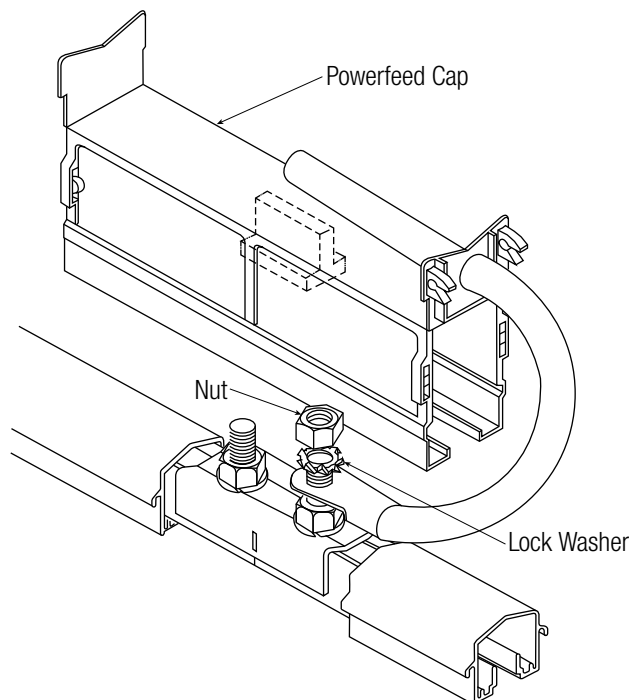

Figure: 14-1

## SECTION 14 - LOW AMP JOINT POWERFEED ASSEMBLY

### NOTE:

- Clean all mating surfaces with 3M Scotch Brite pad, apply a small amount of Electrical Joint Compound (EJC) to all mating parts.
- Apply anti-seize to bolt ends prior to assembly to any stainless steel nuts.

### 14.2 Installation up to and Including 250 Amps

1. Assemble joint to conductor bar as described previously (do not fit washers and nuts).
2. Fit powerfeed top hat assembly to joint assembly. On copper and aluminum conductors apply Electrical Joint Compound (EJC) between mating surfaces.
3. Discard spring washers originally fitted to the joint assembly and fit external tooth lock washers (supplied in the kit) along with nuts and bolts and tighten to a recommended torque of 8 Nm (5-6 ft.-lbs).
4. Fit joint powerfeed cover as shown previously.
5. Cut out grommet using suitable knife and fit over cover.
6. Crimp terminal to supply cable (see list of recommended terminals).
7. Ensure the terminal is properly crimped as failure to do so will result in over-heating on the powerfeed assembly.
8. Fit terminal to powerfeed top hat assembly and secure using washer and bolts. Torque bolt to 8 Nm (5-6 ft.-lbs).
9. There is a second set of hardware (washers and bolt) for use with two cable feeds and should be left tight on powerfeed top hat assembly if only one feed is used.
10. Fit powerfeed joint cover to assembly.
11. Ensure both grommets are fitted into powerfeed cover before closing halves together.
12. Make sure the legs of the cover fit under the conductor cover support ears (a little pressure at points "x-x" will ensure this).
13. Fit powerfeed case clip assembly to powerfeed cover and secure with screws.

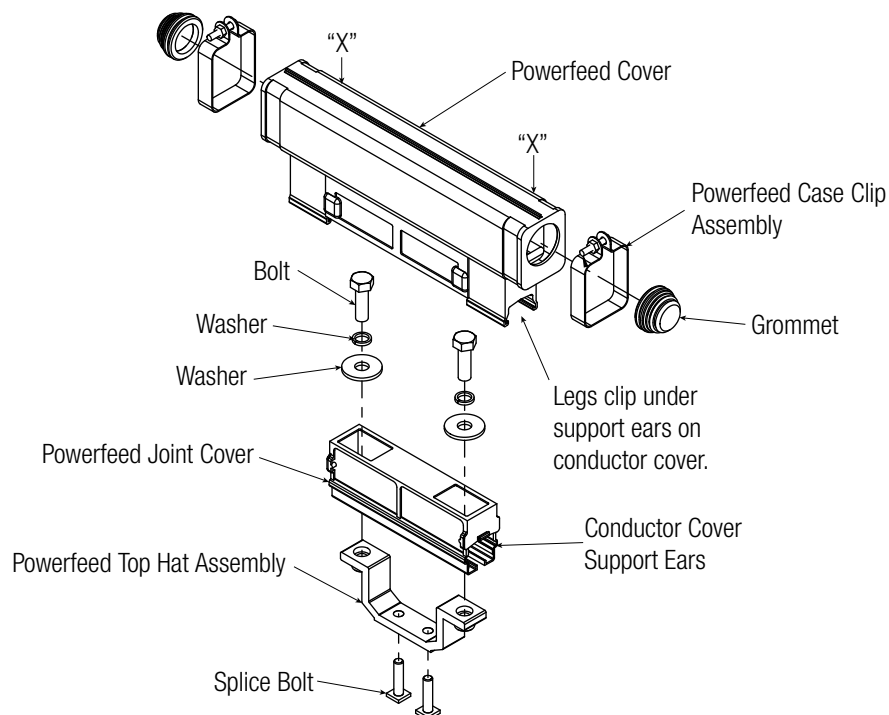

Figure: 14-2

## SECTION 15 - POWERFEED AND COVER ASSEMBLY

### 15.0 Installation over 250 up to 400 Amps

1. Assemble joint to conductor bar as described previously (do not fit washers and nuts).
2. Fit powerfeed top hat assembly to joint assembly. On copper and aluminum conductors apply Electrical Joint Compound (EJC) between mating surfaces.
3. Discard spring washers originally fitted to the joint assembly and fit external tooth lock washers (supplied in the kit) along with nuts and tighten to a recommended torque of 8 Nm (5-6 ft.-lbs).
4. Fit powerfeed joint cover as shown previously.
5. Apply EJC between mating surfaces on powerfeed top hat assembly and powerfeed shunt link.
6. Place powerfeed shunt link over powerfeed top hat assembly and secure with screws. Torque to 8 Nm (5-6 ft.-lbs).
7. Cut out grommet using suitable knife and fit over cable.
8. Crimp terminal to supply cable. (See list of recommended terminals).
9. Ensure the terminal is properly crimped as failure to do so will result in over-heating on the powerfeed assembly.
10. Apply EJC to the center arc of powerfeed shunt link.
11. Fit lug to the center powerfeed shunt link and secure using bolt, washer, and nut in the order shown. Torque to 8 Nm (5-6 ft.-lbs).
12. Fit powerfeed cover to assembly.
13. Ensure both grommets are fitted to powerfeed cover before closing halves together.
14. Make sure the legs of the cover fit under the conductor cover support ears. A little pressure at points "x-x" will ensure this.
15. Fit powerfeed case clip assembly to powerfeed cover and secure with screws.

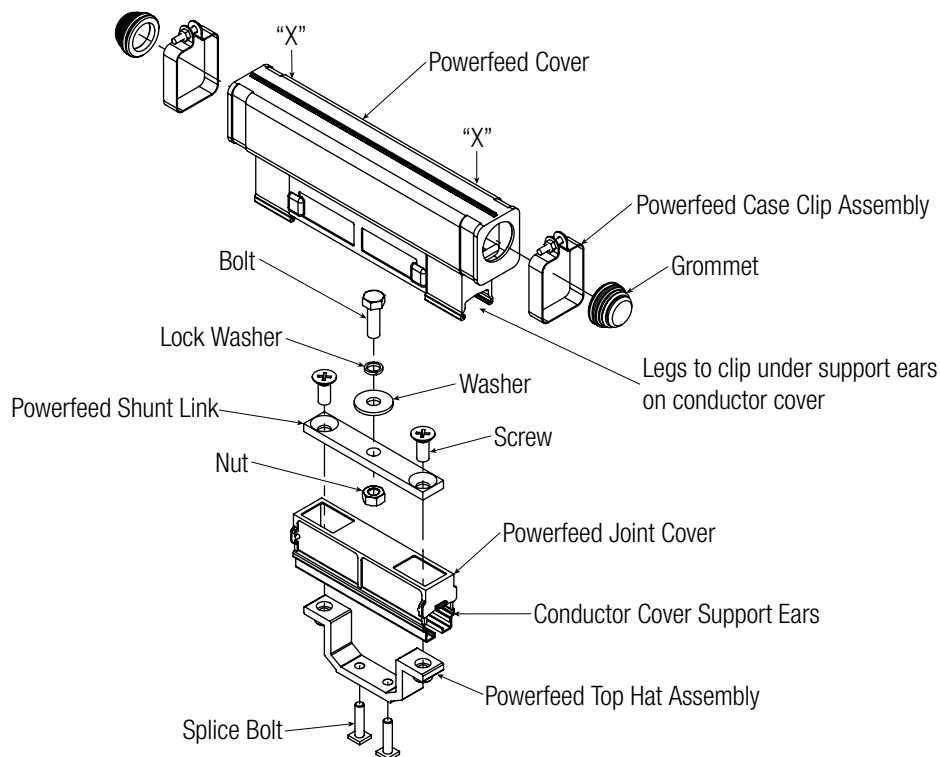
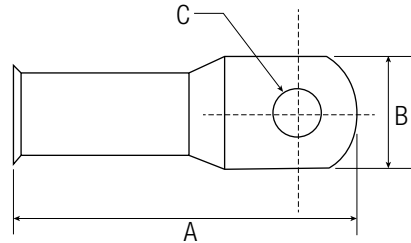

Figure: 15-1

## SECTION 16 - TERMINAL GUIDELINES CHART

16.0 The Thomas and Betts (T&B) terminal part numbers are show below for reference only. Dimensions shown are the maximum allowable sizes. All powerfeeds must have expansion loops incorporated in their installation. Flexible cables are recommended for all powerfeed and collector assemblies. The use of cables with solid "non-strained" conductor is NOT RECOMMENDED.



Powerfeed Part No.	Lug Part No.	T&B Part No.	Dim "A"	Dim "B"	Dim "C"	Cable Size (AWG)
XA-310910B	XA-310101	E72	1.32	.60	5/16	6
	XA-310201	F72	1.35	.60	5/16	4
	XA-310301	G972	1.59	.69	5/16	1-2
	XA-310601	J972	1.94	.84	5/16	1/OAN-2/0
	XA-310401	L973	2.25	1.04	3/8	3/OAN-4/0
XA-310912B	XA-310701	M972	2.28	1.12	5/16	4/OAN - 250 kcmil
	XA-310501	54178	2.33	1.25	5/16	300 kcmil
XA-310911	XA-310101	E71	1.13	.48	1/4	6
XA-310034B	XA-310101	D71	1.13	.48	1/4	8

## SECTION 17 - 100 AMP COLLECTOR MOUNTING DETAILS

### 17.0 XA-SL2C-100S-1M Single Collector - Figure 17-1

17.0.1 When stationary, single collector is rated for 50 continuous amps on copper or galvanized steel bars, and 25 continuous amps on aluminum-stainless steel bar.

### 17.1 XA-SL2C-100T-1M Tandem Collector - Figure 17-2

17.1.1 When stationary, tandem collector is rated for 100 continuous amps on copper or galvanized steel bars, and 50 continuous amps on aluminum-stainless steel bar.

### 17.2 Tools Needed

- Socket Wrench  
    > 16 mm
- Steel rule or suitable tape measure
- Hex wrench  
    > 4mm
- Cable Stripper

### 17.3 Installation

1. Attach collector mounting bracket to a suitable support at the correct setting height (see Figs. 17-1 and 17-2).
2. Remove the collector clamp and place collector on the mounting bracket.
3. Ensure collectors are directly aligned with the center of the conductor bars. Collector arms should be parallel with the running surface.
4. Replace collector clamp and tighten Bolt 1 and Bolt 2 to a recommended torque of 24.4-27.1 Nm (18-20 ft.-lbs).
5. For customer installed cable on the collectors, there must be 18" for 100 amp and 19.5" for 200 amp of cable length from the exit of the cable clamp to the entrance of the collector head. Reference the striped cable sections of **Figures 17-1, 17-2, 18-1, 18-2.**

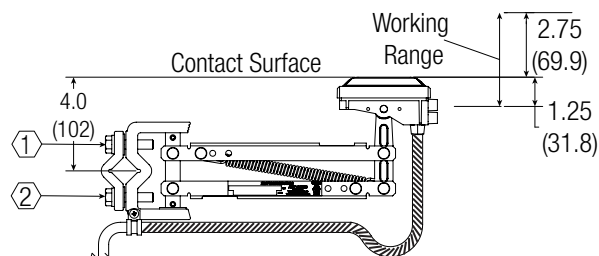

Figure: 17-1

#### NOTE:

- Cable length between the exit of the cable clamp and the cable entry hole on the collector head should be 18" for 100 Amp Collectors and 19.5" 200 Amp Collectors to ensure proper head movement on the collectors.

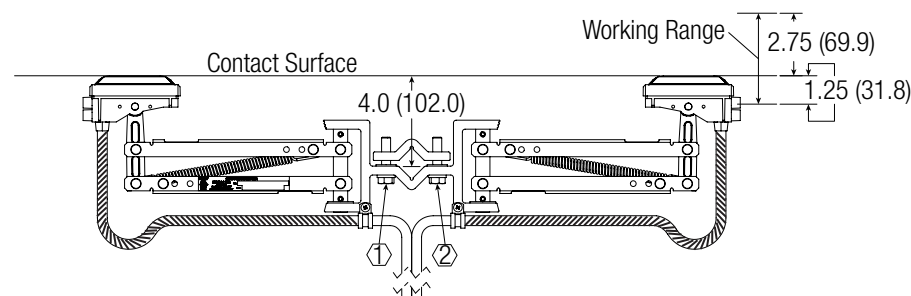

Figure: 17-2



## SECTION 18 - 200 AMP COLLECTOR MOUNTING DETAILS

### NOTE:

- Torque mounting hardware per the chart below.
- In the stationary position, these collectors are UL rated at 100 Amps continuous-duty on copper, and 50 Amps on aluminum-stainless steel.

Collector Base Material	Torque Spec
Aluminum	24.4 to 27.1 Nm (18-20 ft.-lb)

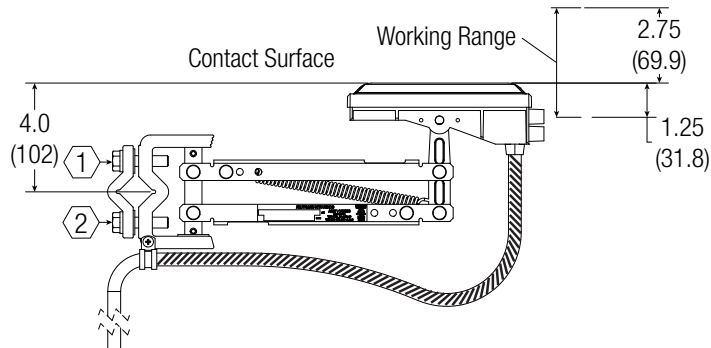

Figure: 18-1

### NOTE:

- Cable length between the exit of the cable clamp and the cable entry hole on the collector head should be 18" for 100 Amp Collectors and 19.5" 200 Amp Collectors to ensure proper head movement on the collectors.

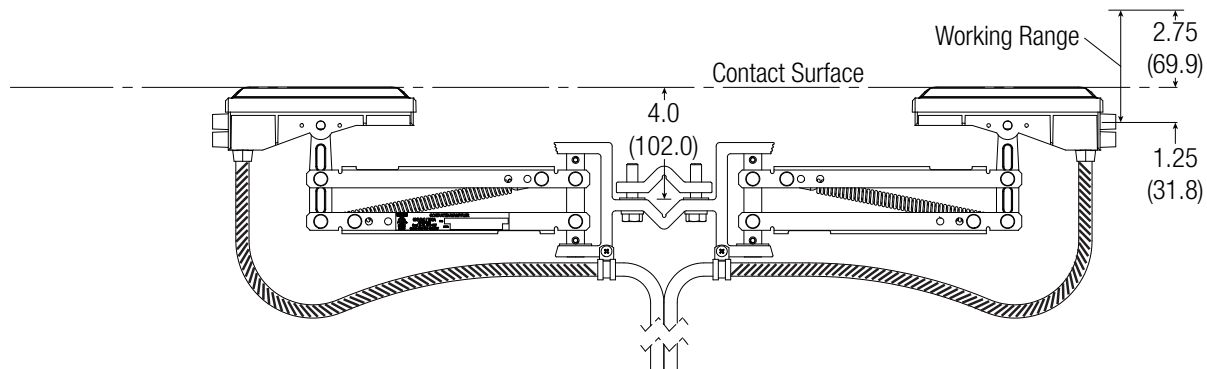

Figure: 18-2

### 18.0 Ground Flag Installation

1. The ground flag should be oriented on the ground collector with the flag facing away from the other phase conductors as to prevent the ground conductor from being inserted into any of the phase rails.
2. Align the two 3.2 mm through holes located near the pivot post on the head with the two holes on the ground flag.
3. The supplied M3 locking nuts should be inserted into the flag where the hexagonal nut bosses are molded into the flag. Orient the nylon section of the nuts facing away from the collector.
4. Insert the two M3 x 30 screws through the collector head and into the flag and flag nuts.
5. Tighten the M3 screws on 0.9 Nm (8 in.-lb).

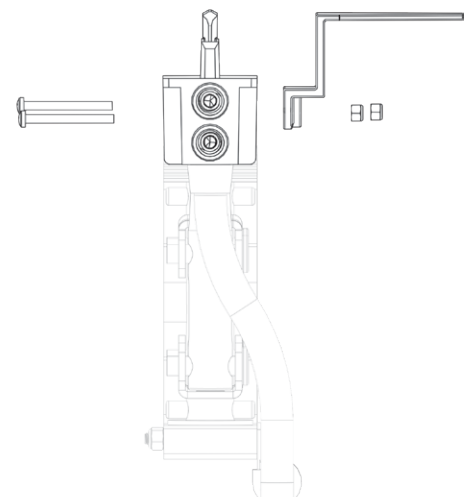

Figure: 18-3

## SECTION 19 - CUSTOMER SUPPLIED CABLE

### 19.0 Installation

1. Strip customer-supplied cable back 13-15 mm (0.5-0.6") using a suitable cable stripping tool.
2. Loosen Screw Number 1.
3. Push customer-supplied cable into entry hole.
4. Tighten Screw Number 1 fully and ensure that the cable is clamped firmly into position.
5. Ensure that the cables do not restrict the free movement of the collector arm or collector head. The collector head must be free to track on the conductor bar within the movement tolerances noted on Page 31.
6. We highly recommended the use of flexible, finely stranded cables to wire collectors. The use of cables with solid conductors is not recommended.

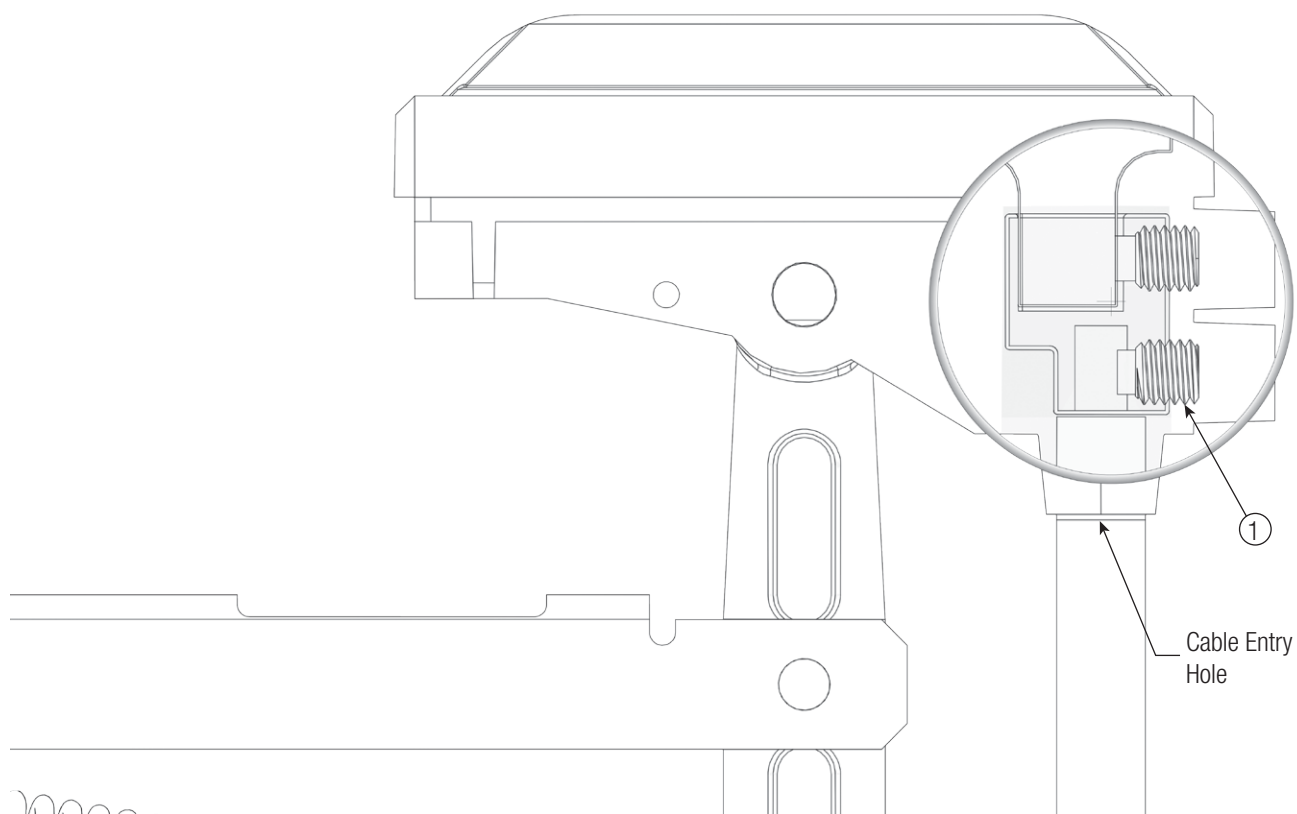

Figure: 19-1

## SECTION 20 - TRANSFER CAP ASSEMBLY

### 20.0 Tools Needed

- A/F Wrench  
    > 13mm
- Soft Mallet

### 20.1 Transfer Cap Installation

1. Mark Conductor cover 22mm (0.87" in from end of cover).
2. Gently tap transfer cap onto bar and cover assembly using a soft mallet.
3. Line up back edge of transfer cap with mark on cover.
4. Install transfer cap into support bracket (not shown) at 43mm (1.7") centers.
5. Fit nut and washers in order shown.
6. Tighten nut to a recommended torque of 28.4 Nm (20-21 ft.-lbs).

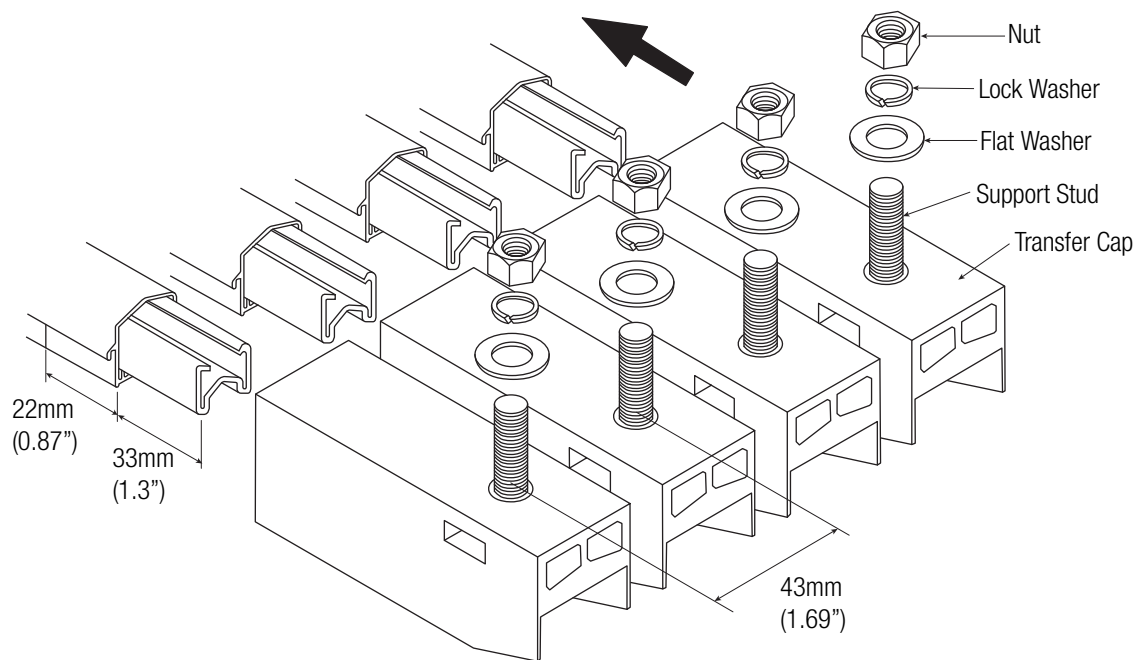

Figure: 20-1

## SECTION 20 - TRANSFER CAP ASSEMBLY

### 20.2 Transfer Cap Mounting Details

20.2.1 Side Transfer Cap showing maximum alignment tolerance.

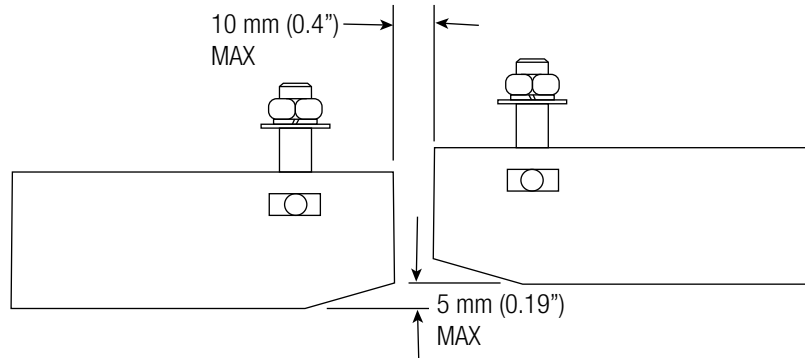

Figure: 20-2

20.2.2 Plan view of transfer caps showing maximum alignment tolerance.

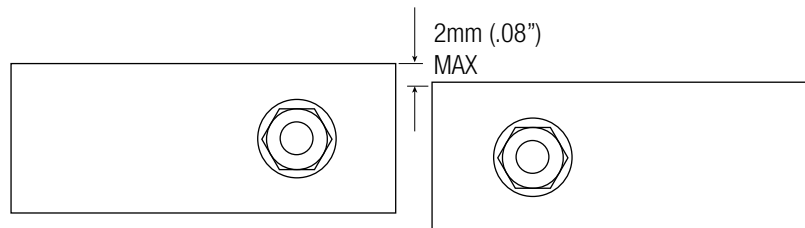

Figure: 20-3

#### NOTE:

- Where transfer caps are used in a system, tandem collectors must be used.

## SECTION 21 - ASSEMBLY OF ISOLATION SPLICE ASSEMBLIES

### 21.0 Tools Needed

- A/F open ended wrench  
> 10 mm

### 21.1 Installation

1. Fit bolt into joint plate. Ensure tab captivates the head on the setscrew.
2. Slide bolt and joint plate into conductor bar ends respectively.
3. Place cap over bolt.
4. Fit washers and nuts in the order shown.
5. Tighten nuts to a recommended value of 8 Nm (5-6 ft-lbs).

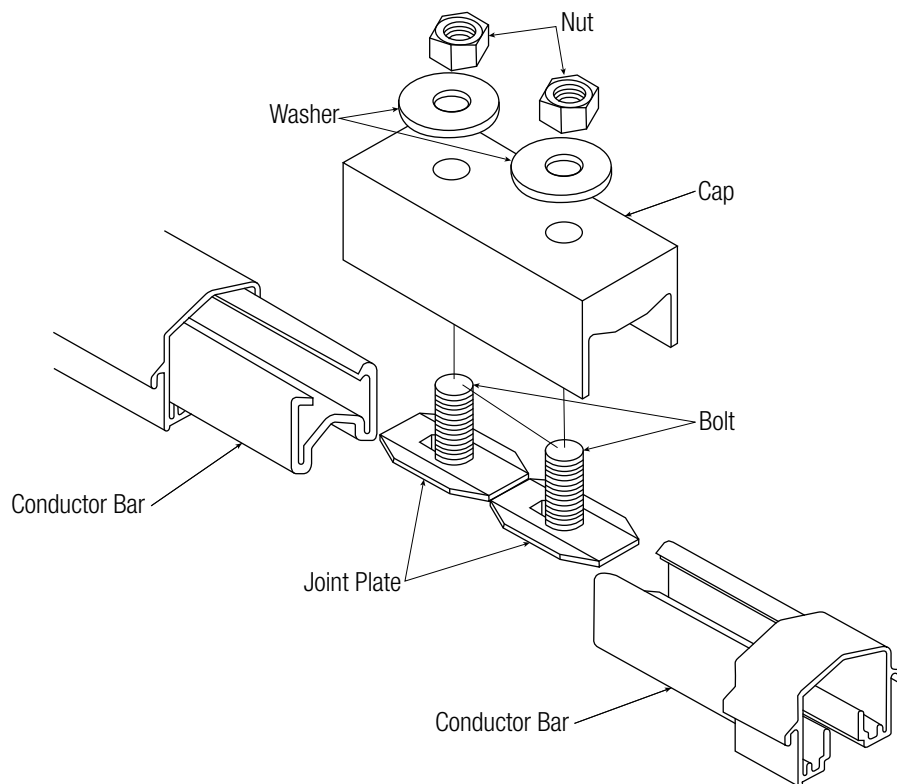

Figure: 21-1

## SECTION 22 - SYSTEM MAINTENANCE AND INSTALLATION NOTES

### 22.0 Maintenance Notes

1. Contact shoes should be checked for wear on a monthly basis until a wear pattern can be established.
2. Check alignment of collector and conductor bars. Base of collector should be directly in-line with associated conductor.
3. Check conductor system to ensure no damage to insulation cover.
4. In environments that are subject to considerable build up of dust, especially conductive dust, remove this dust at regular intervals by brushing.
5. Check collector pivot points are free from any contamination.
6. Uneven shoe wear indicates less than optimal collector alignment.

### 22.1 Installation Notes

1. Ensure all power is disconnected before attempting to install or maintain the system.
2. Ensure all electrical joints are free from any contamination.
3. Ensure correct alignment and location of support brackets.
4. Ensure conductor joints are not against hanger clamps. Adequate clearance must be allowed for expansion and contraction.
5. Ensure correct alignment of collector with conductor bar. Collector arms should be parallel with contact surface.
6. Ensure all power cables are flexible to allow expansion and contraction of the conductor bar system.
7. Ensure all armored cables are terminated into a suitable junction box and only flexible cables are installed into the powerfeed assemblies.
8. Ensure conductor bars **DO NOT** support the weight of the feed cables.
9. Conductix-Wampfler recommends that the first accessible conductor bar should be the ground bar.

## SECTION 23 - COLLECTOR CONTACT SHOE AND SHOE HOLDER

### NOTE:

- Collector contact shoe is supplied as replacement part no. XA-577940 for 100A collectors and part no. XA-577947 for 200A collectors.

### 23.0 Tools Needed

- Hex Wrench
  - > 4mm for 100A collector
  - > 5mm for 200A collector

### 23.1 Replacement Instructions

1. Loosen upper set screw with hex wrench.
2. Remove shoe by pulling upward, take care not to lose the shim located between the shoe and the setscrew. See **Figure: 23-1**.
3. Replace shoe with new shoe. Place shim in pocket between setscrew and shoe, and install new shoe into collector head. See **Figure: 23-2**.
4. Tighten set screw to 1.69 Nm (15 in.-lb).

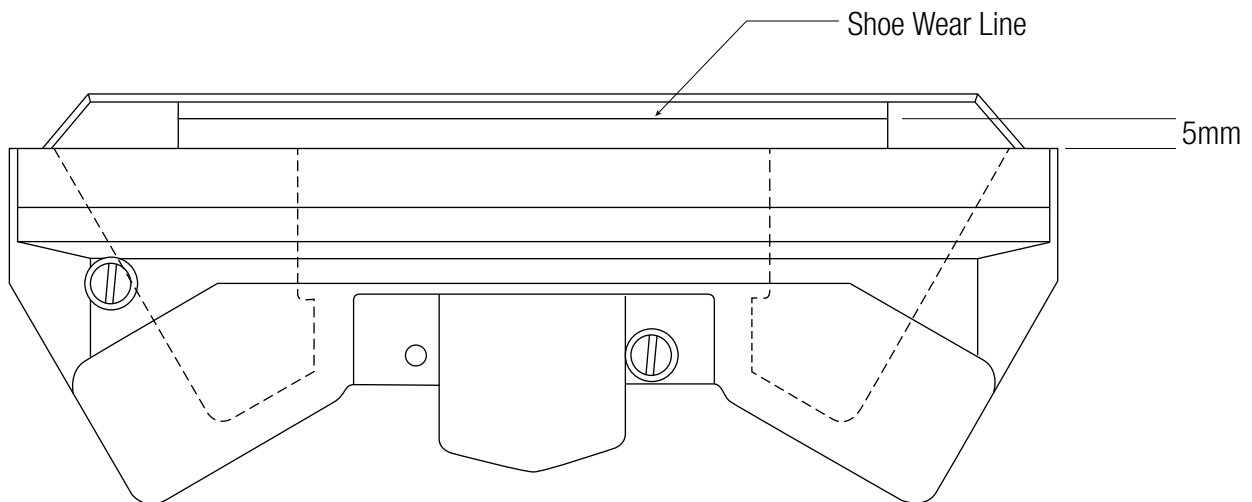

Figure: 23-0

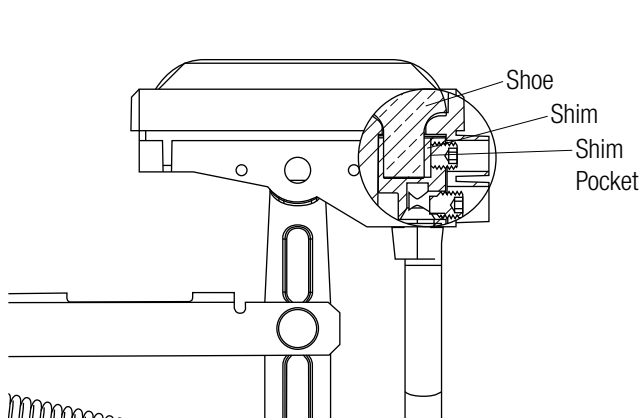

Figure: 23-1

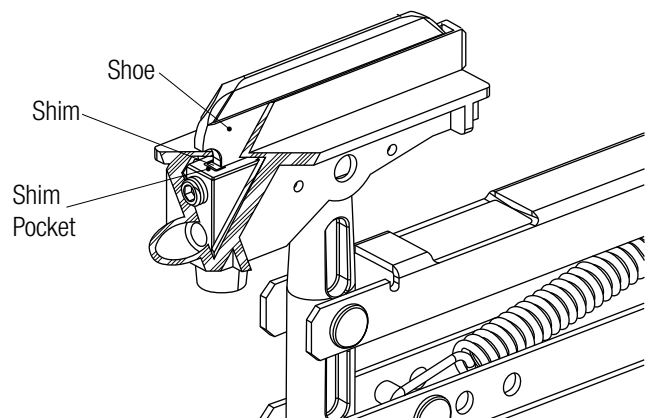

Figure: 23-2

## SECTION 24 - PICKUP GUIDES

### 24.0 Overview

24.0.1 For areas in which the collector must be driven in or out of the conductor rail system, pickup guides are used in combination with current collectors provided for this purpose. The speed for pickup guide entry must not exceed 60 m/min (196 ft/min) and pickup guides must be considered as wearing parts.

24.0.2 Installation tolerances must be taken into consideration. Simultaneous alignment gaps with maximum tolerances in the X and Y directions are not permitted.

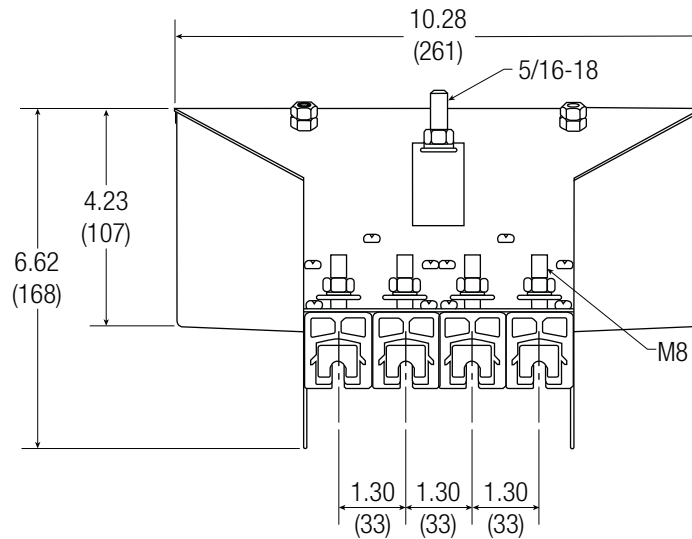

Figure: 24-1

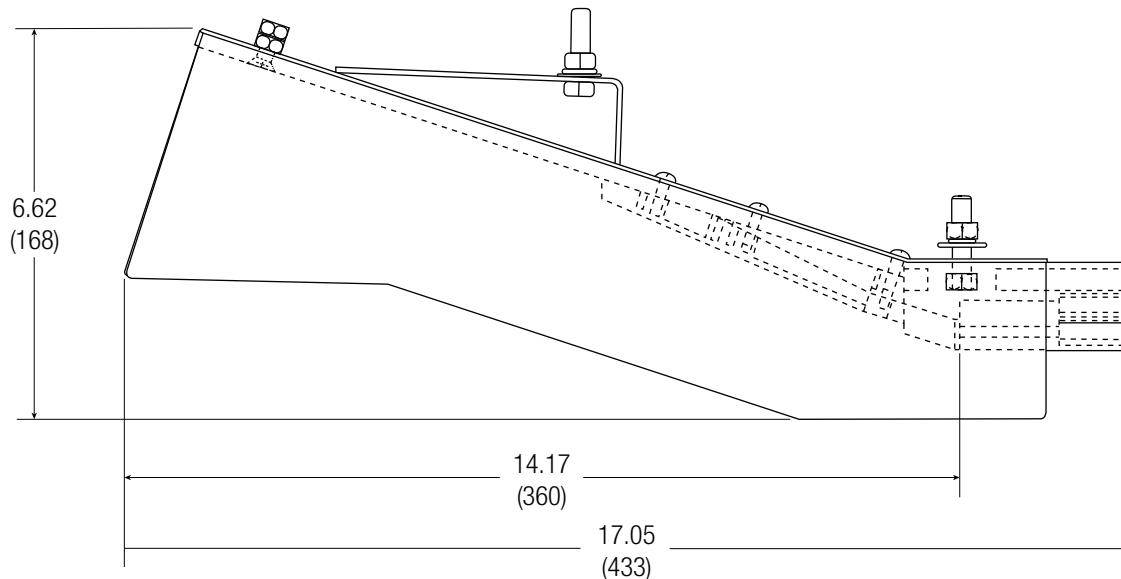

Figure: 24-2



## SECTION 24 - PICKUP GUIDES

### 24.1 Dimensions

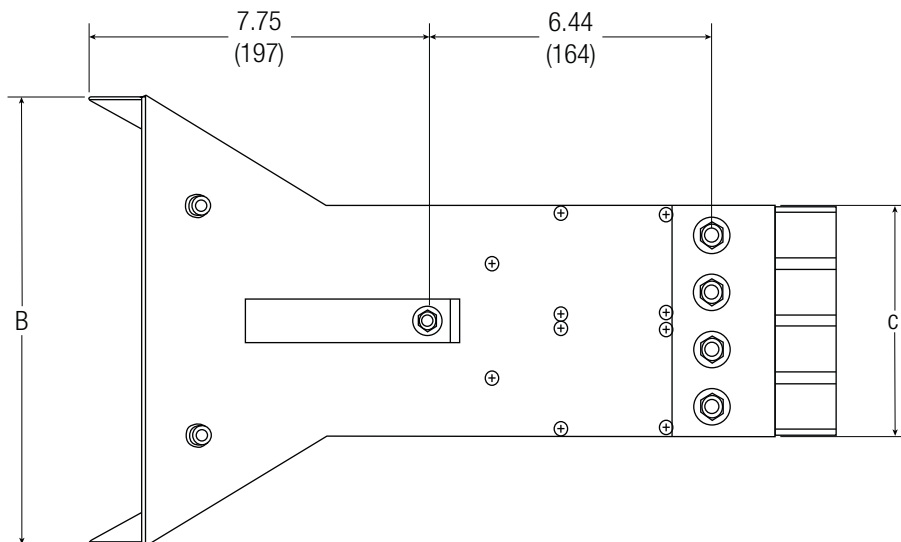

Figure: 24-3

Dimensions	Number of Poles			
	1	2	3	4
B	2.96" (75)	7.67" (195)	8.97" (228)	10.26" (261)
C	1.51" (38)	2.74" (70)	4.04" (103)	5.32" (135)

24.1.1 The pickup guide centers the current collector with a maximum lateral and vertical alignment tolerance of  $\pm 0.50"$  (12.7).

24.1.2 In installations with pickup guides, a corresponding number of current collectors must be available, and mounted in intervals that ensure that just the necessary number of current collectors needed for momentary power requirements are in use.

### DANGER

The user must ensure that the current collector between the pickup guides are disconnected from power or are protected against accidental contact!

## SECTION 24 - PICKUP GUIDES

### 24.2 Hanger clamp spacing for installations with pickup guides

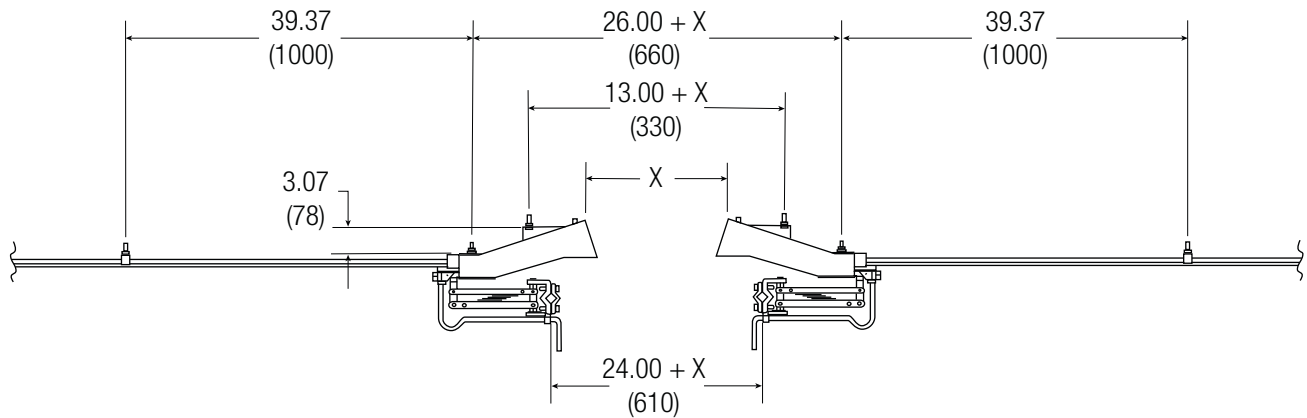

Figure: 24-4

### ! CAUTION

The middle distance (phase distance) between two conductors is 43 mm. This is reduced to 33 mm at the pickup guide in order to ensure that the collectors enter the pickup guide precisely.

### 24.3 Hanger Clamp Spacing For Installations With Pickup Guide

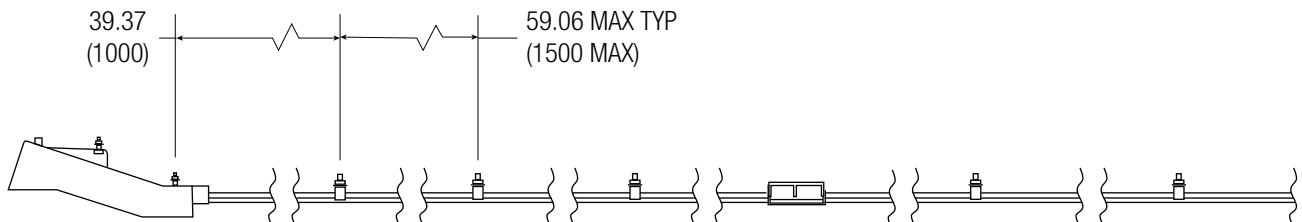

Figure: 24-5

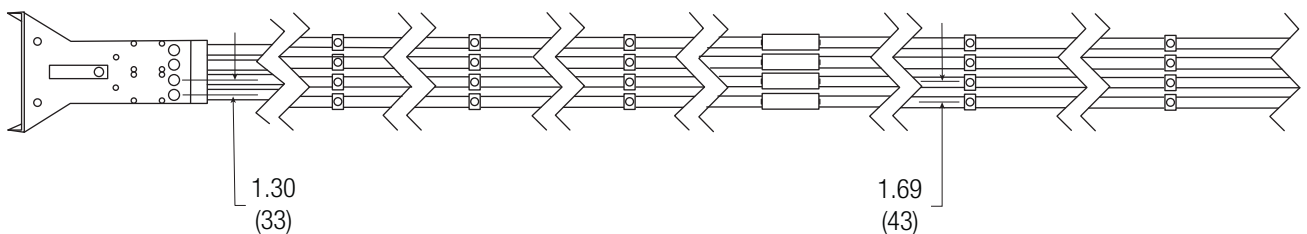

Figure: 24-6

## SECTION 24 - PICKUP GUIDES

### 24.4 Assembly Instructions For 1, 2, 3, & 4-way Pickup Guide

1. Remove nut, lock washer, and flat washer from transfer caps. Remove transfer caps from pickup guide.
2. Insert the ends of the conductor rails into the end of the transfer caps. Ensure the rails are fully seated. A soft mallet may be used to gently tap the transfer cap onto the bar and cover assembly.
3. Ensure any hanger clamps are at least one meter back from the transfer cap.
4. Squeeze transfer caps together and fit pickup guide over support stud.
5. Fit transfer cap support bracket over support stud and torque to 28.4 Nm (20-21 ft.-lbs).

**NOTE:** Bracket width must not exceed 40mm (1.55").

6. Attach ramp end of the pickup guide to a bracket and torque to 28.4 Nm (20-21 ft.-lbs).

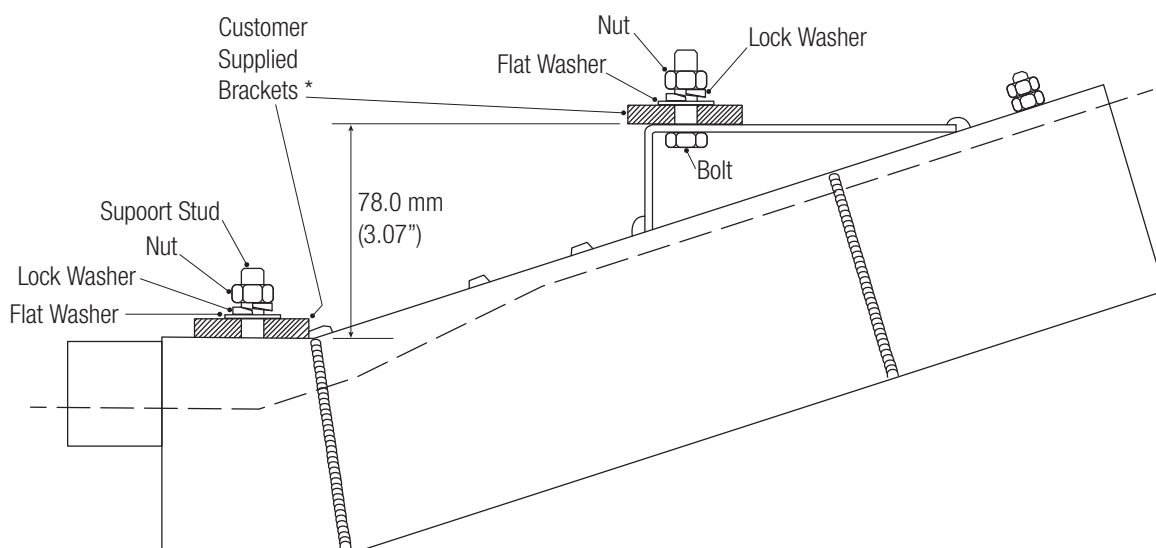
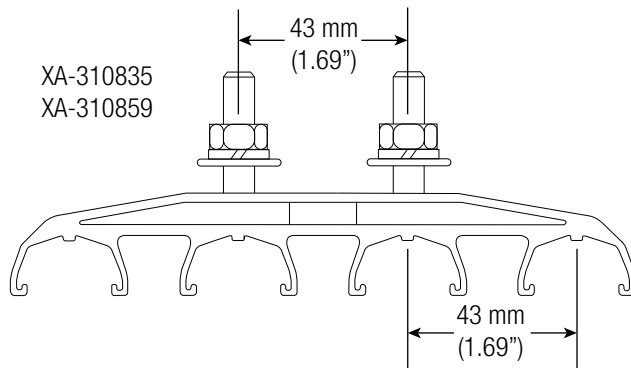
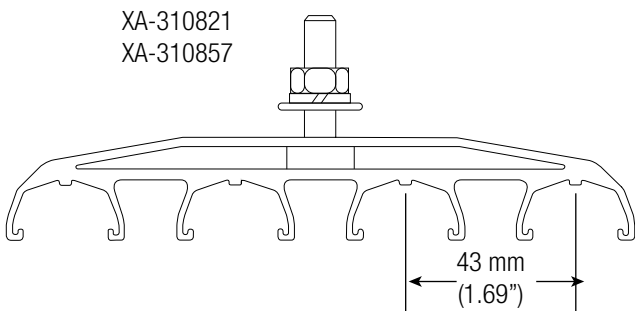
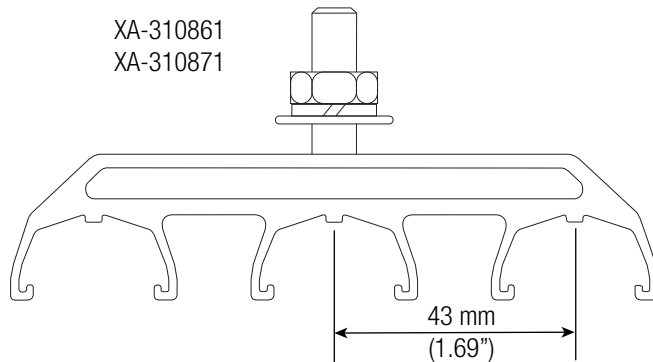
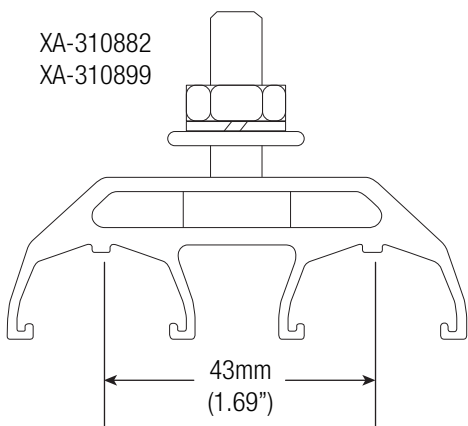
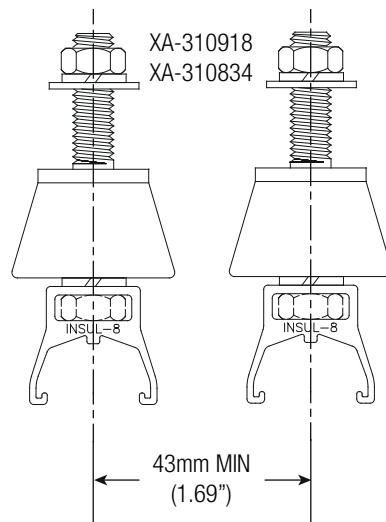
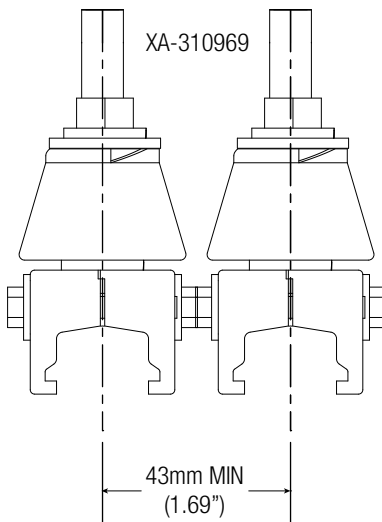
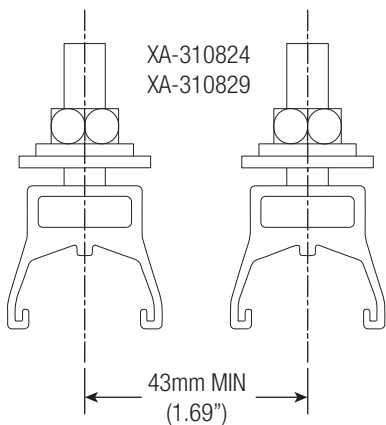

Figure: 24-7

**NOTE:** When using pickup guides, collector part XA-SL2C-100SX-1M-PG must be used. Please contact the factory when ordering.

# SECTION 25 - HANGER CENTERS DIAGRAM



# SECTION 26 - CONDUCTOR BAR DE-RATING CHART

## Conductor De-rating

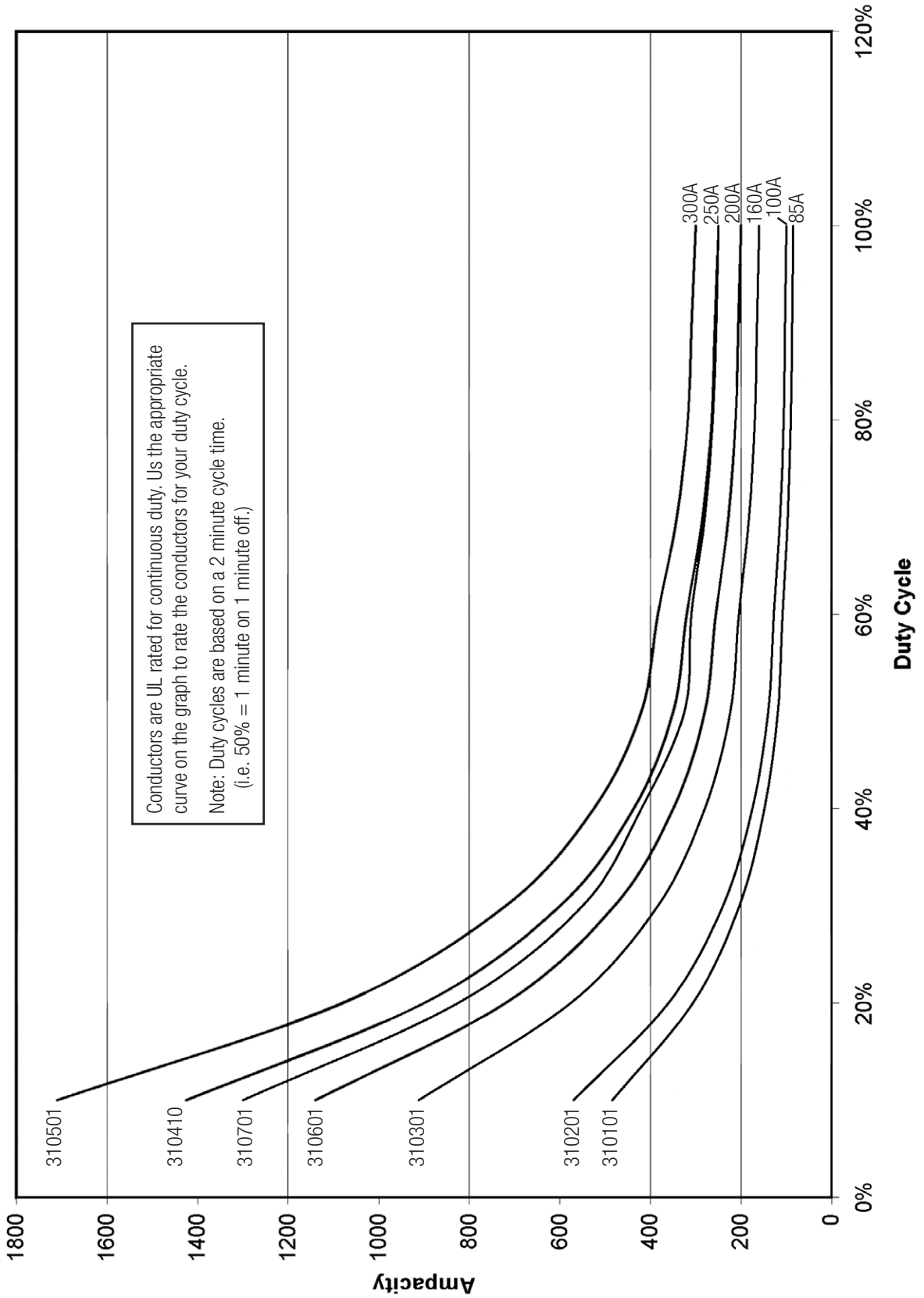

# www.conductix.us

## Conductix-Wampfler

has just one critical mission:  
To provide you with energy and  
data transmission systems that  
will keep your operations up  
and running 24/7/365.

To contact your nearest  
sales office, please refer to:

[www.conductix.contact](http://www.conductix.contact)

