

# Push Button Pendants Manual

## 80 Series

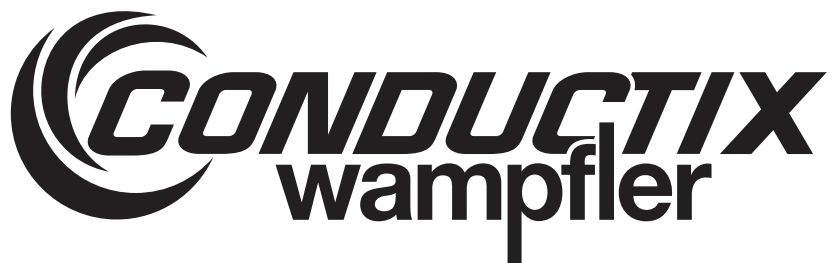

# CONDUCTIX INCORPORATED

The technical data and images which appear in this manual are for informational purposes only. **NO WARRANTIES, EXPRESS OR IMPLIED, INCLUDING WARRANTIES OF MERCHANTABILITY OR FITNESS FOR A PARTICULAR PURPOSE, ARE CREATED BY THE DESCRIPTIONS AND DEPICTIONS OF THE PRODUCTS SHOWN IN THIS MANUAL.** Conductix makes no warranty (and assumes no liability) as to function of equipment or operation of systems built according to customer design or of the ability of any of its products to interface, operate or function with any portions of customer systems not provided by Conductix.

Seller agrees to repair or exchange the goods sold hereunder necessitated by reason of defective workmanship and material discovered and reported to Seller within one year after shipment of such goods to Buyer.

Except where the nature of the defect is such that it is appropriate, in Seller's judgment, to effect repairs on site, Seller's obligation hereunder to remedy defects shall be limited to repairing or replacing (at Seller's option) FOB point of original shipment by Seller, any part returned to Seller at the risk and cost of Buyer. Defective parts replaced by Seller shall become the property of Seller.

Seller shall only be obligated to make such repair or replacement if the goods have been used by Buyer only in service recommended by Seller and altered only as authorized by Seller. Seller is not responsible for defects which arise from improper installation, neglect, or improper use or from normal wear and tear.

Additionally, Seller's obligation shall be limited by the manufacturer's warranty (and is not further warranted by Seller) for all parts procured from others according to published data, specifications or performance information not designed by or for Seller.

Seller further agrees to replace or at Seller's option to provide a refund of the sales price of any goods that do not conform to applicable specifications or which differ from that agreed to be supplied which non-conformity is discovered and forthwith reported to Seller within thirty (30) days after shipment to the Buyer. Seller's obligation to replace or refund the purchase price for non-conforming goods shall arise once Buyer returns such goods FOB point of original shipment by Seller at the risk and cost of Buyer. Goods replaced by Seller shall become the property of Seller.

There is no guarantee or warranty as to anything made or sold by Seller, or any services performed, except as to title and freedom from encumbrances and, except as herein expressly stated and particularly, and without limiting the foregoing, **there is no guarantee or warranty, express or implied, of merchantability or of fitness for any particular purpose or against claim of infringement or the like.**

Seller makes no warranty (and assumes no liability) as to function of equipment or operation of systems built to Buyer's design or of the ability of any goods to interface, operate or function with any portions of Buyer's system not provided by Seller.

Seller's liability on any claim, whether in contract, tort (including negligence), or otherwise, for any loss or damage arising out of, connected with, or resulting from the manufacture, sale, delivery, resale, repair, replacement or use of any products or services shall in no case exceed the price paid for the product or services or any part thereof which give rise to the claim. In no event shall Seller be liable for consequential, special, incidental or other damages, nor shall Seller be liable in respect of personal injury or damage to property not the subject matter hereof unless attributable to gross misconduct of Seller, which shall mean an act or omission by Seller demonstrating reckless disregard of the foreseeable consequences thereof.

Seller is not responsible for incorrect choice of models or where products are used in excess of their rated and recommended capacities and design functions or under abnormal conditions. Seller assumes no liability for loss of time, damage or injuries to property or persons resulting from the use of Seller's products. Buyer shall hold Seller harmless from all liability, claims, suits and expenses in connection with loss or damage resulting from operation of products or utilization of services, respectively, of Seller and shall defend any suit or action which might arise there from in Buyer's name - provided that Seller shall have the right to elect to defend any such suit or action for the account of Buyer. The foregoing shall be the exclusive remedies of the Buyer and all persons and entities claiming through the Buyer.

# INDEX

## 1.0 Specifications

- 1.1 Mechanical Specifications
- 1.2 Electrical Specifications
- 1.3 Environmental Specifications

## 2.0 Assembly

- 2.1 Disassembly of the enclosure
- 2.2 Mounting Switches
- 2.3 Mounting mushroom head selector and key switches
- 2.4 Cable installation
- 2.5 Button legends
- 2.6 Vertical legends
- 2.7 Reassembly of the enclosure

## 3.0 switch schematics

# 1.0 SAFETY

## 1.1 Mechanical Specifications

- 1.1.1 Recommended cable: Pendant Control cable or equivalent, copper conductors 75oC
- 1.1.2 Bushings are available for cables ranging from 0.30" to 1.16" in diameter.
- 1.1.3 External Strain Relief: An external strain- relief tie point on the bushing collar has been supplied for the connection of an external-relief wire attached to the upper junction box of the cable. Pre-assembled pendants are supplied with an "S" hook for strain relief attachment.

- 1.1.4 Torque values:
  - Enclosure Screws: 15in-lbs.
  - Switch Mounting Screws: 20in-lbs.
  - Internal Cable Clamp: 10in-lbs.
  - Bushing Clamp: 25in-lbs.
  - Terminal Screws: 10in-lbs.

## 1.2 Electrical Specifications

- 1.2.1 Contacts rated 5A at 120V AC, continuous resistive load or clamped inductive load, 2A at 240V-AC, for 500,000 operations.

- 1.2.2 **WARNING: Turn off all power supply sources and follow Lockout/Tagout Procedures while working on pendant.**

## 1.3 Environmental Specifications

- 1.3.1 **WARNING! Use only mild detergents for cleaning pendant housings. Solvents and brake cleaners will damage the housings.**

# 2.0 SPECIFICATIONS

## 2.1 Disassembly of the Enclosure (See Figure 1)

- 2.1.1 Remove Bushing and Collar by loosening the bushing collar screws.
- 2.1.2 Remove Enclosure Cover by loosening the enclosure screws.

DISASSEMBLY AND ASSEMBLY OF THE ENCLOSURE FIGURE 1

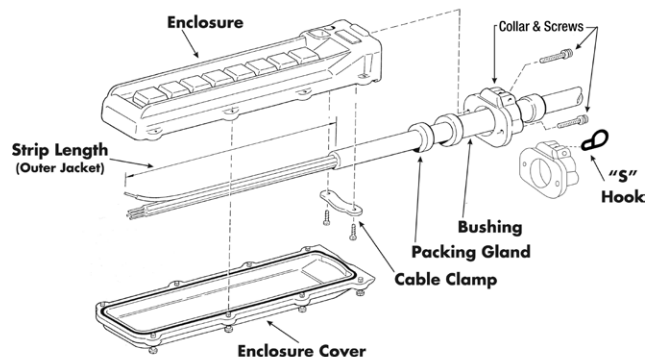

## 2.2 Mounting Switches (See Figure 1 & Figure 2, page 4)

- 2.2.1 Skip to Section 2.4 if pendant is preassembled.
- 2.2.2 Remove Enclosure Cover if not already removed.
- 2.2.3 Remove the Silicon Switch Boot for switches not requiring a boot. On/Off switches are provided with green and red boots. Swap boots as needed before installing switches.
- 2.2.4 Fit switch into Enclosure casing, aligning screw holes. Ensure Switch Boot is properly in place. Damaged or incorrectly installed boots will not seal properly, and moisture may leak inside the enclosure. Tighten Switch Screws securely. (Depending on switch, there will be either two or four screws.) Torque to 20 in-lbs.

BUTTON SWITCH FIGURE 2

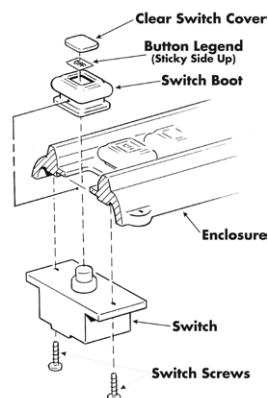

## 2.0 SPECIFICATIONS

### 2.3 Mounting Mushroom Head and Selector, Switches

- 2.3.1 Remove Enclosure Cover if not already removed.
- 2.3.2 Install Switch Frame by inserting it from the front of the enclosure through the square hole. Make sure the gasket and legend are in the correct position. From the back, install the Tightening Ring, making sure to align notches of Tightening Ring with tabs of Switch, and tighten (see figure 3a).
- 2.3.3 Install Switch to enclosure by using two screws provided. Make sure the designated letters on the Switch read correctly from the top of the enclosure.
- 2.3.4 Follow section 2.4 for cable installation, and wire as needed. (See Switch Schematics Section 3.0 Pages 6-7).
- 2.3.5 Apply appropriate legend label from the Selector Legend Sheet. Note: Legend Sheet is provided with Selector, Mushroom and on/off switches.

**Important:** Firmly fasten Tightening Ring to secure Frame. Align the notches for the Tightening Ring with the screw holes in the Enclosure. The Switch has tabs that fit into the cut-outs on the Frame. Misalignment will prevent the switch from seating properly

Figure 3a

Inside of Enclosure as viewed from back of pendant with Enclosure Cover removed.

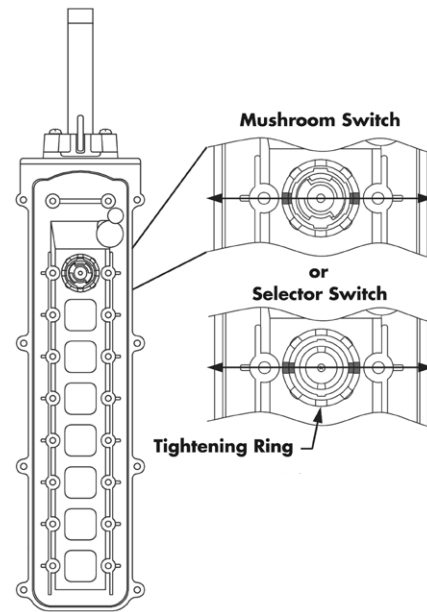

### 2.4 Cable Installation (See Figure 1, Page 3)

- 2.4.1 Disassemble pendant according to instructions in Section 2.1
- 2.4.2 Cut the two Packing Glands apart and use only one. The Glands are labeled in millimeters. (See Table 2.4.2). Be sure to choose the correct cable gland for the cable used. If the cable gland is loose, an adequate seal will not be achieved and moisture may leak inside the enclosure.

Part Number	Diameter / Inches	Diameter / Millimeters
34411	.295 - .354	7.50 - 9.00
	.346 - .413	8.80 - 10.5
34412	.406 - .472	10.3 - 12.0
	.464 - .531	11.8 - 13.5
34413	.524 - .591	13.3 - 15.0
*39825	.583 - .650	14.8 - 16.5
34414	.642 - .709	16.3 - 18.0
	*39826	.701 - .768
34415	.760 - .827	19.3 - 21.0
	.819 - .886	20.8 - 22.5
34416	.878 - .945	22.3 - 24.0
	.937 - 1.004	23.8 - 25.5
34417	.996 - 1.063	25.3 - 27.0
	1.055 - 1.122	26.8 - 28.5
34418	1.114 - 1.161	28.3 - 29.5

\* 39825 & 39826 used on enclosures with large collar.

- 2.4.3 Pull cable through the Bushing Collar, Bushing, and Packing Gland. Then feed the cable through the cable hole of Enclosure casing. Determine amount of outer jacket that needs to be stripped. Strip the outer jacket.
- 2.4.4 Position cable so that the Cable Clamp will clamp the jacketed part of the cable. Secure the cable by installing the Cable Clamp and tightening Cable Clamp Screws.
- 2.4.5 Secure the Bushing and Collar firmly to the enclosure casing with the two Collar Screws after adjusting wiring length and clamping cable.
- 2.4.6 NOTE: Tighten all applicable screws using the recommended torque values in Section 1.1.4
- 2.4.7 Connect wiring connections to the push button terminals using UL listed ring terminals. (See Switch Schematics on Page 6-7.) Wire lengths must be a minimum of 6" long according to NEC code. Route wires along the inside of housing. Never leave wires on top of switch due to interference with back cover installation.

## 2.0 SPECIFICATIONS

### 2.5 Button Legends PN: 34326

(A Button Legend Sheet is supplied with all pre-assembled pendants. Switch covers are sent loose with all pendants.)

- 2.5.1 Select the appropriate label from the Legend Sheet. Carefully remove from sheet. Labels have adhesive on the printed side. Carefully place label on larger side of the Clear Switch Cover.

- 2.5.2 Place one edge of labeled Switch Cover in appropriate Switch Boot. Complete installation by gently lifting rim of boot over remaining edges of Switch Cover.

### 2.6 Vertical Legends PN: 34327

- 2.6.1 Select the appropriate label from the Legend Sheet. Carefully remove from sheet. Labels have adhesive on the backside. Carefully place label on Enclosure casing beside appropriate switch.

### 2.7 Reassembly of the Enclosure

(See Figure 1, Page 3)

- 2.7.1 Ensure that all conductors are insulated from one another.  
 2.7.2 Ensure that the Enclosure Seal Gasket is in place in the slot of the Enclosure Cover.  
 2.7.3 Remove all wire waste and debris from inside the Enclosure Case.  
 2.7.4 Install the Enclosure Cover and tighten Enclosure Screws.

## 3.0 SWITCH SCHEMATICS

34292 34293			37114 37199		
34308 34309 34310				34297	
34321 34322			34296 34297 34298		
34294 34295			34298	34298 - Same as 34297 but with delayed opening of contacts 7 & 8 "Break - Before - Make" contact arrangement	
34305 34306 34307			34307	34323	

# 3.0 SWITCH SCHEMATICS

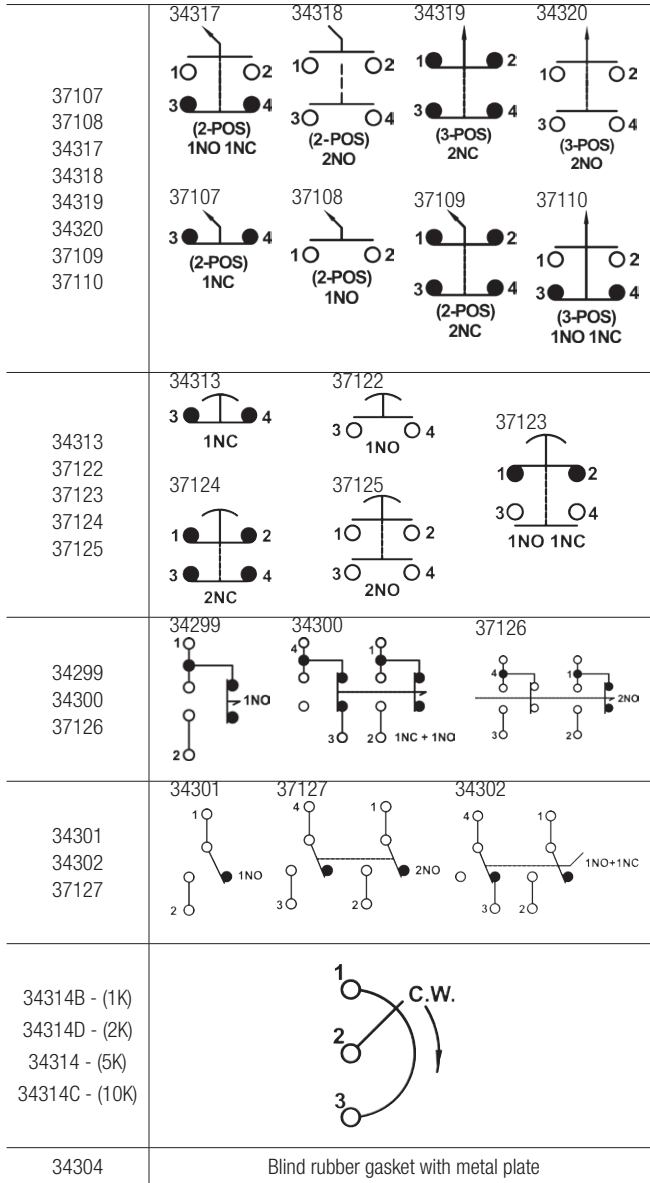

P/N	Switch Description
34292	Maintained On-Off, 1NO
34293	Maintained On-Off, 1NC 1NO
34308	Momentary On-Off, 1NC, 1NO
34309	Momentary, 2NO, w/o interlock
34310	Momentary, 2NC, 2NO, w/o interlock
34321	Momentary, 4 NO w/interlock
34322	Momentary, 4NC, 4NO, w/interlock
34294	Momentary, 2NO w/interlock
34295	Momentary, 2NC, 2NO w/interlock
34305	Momentary, 1NC
34306	Momentary, 1NO
34307	Momentary, 1NC, 1NO
37114	Momentary, 2NC
37199	Momentary, 2NO
34296	2-Speed, 4NO, w/interlock
34297	2-Speed, Double Contact, 2NC, 4NO, w/interlock
34298	2-Speed, Double Contact, 2NC, 2NO x 2 w/interlock (Late Break)
34323	3-Speed, 1NC, 6NO
37107	2 Position Selector, 1NC
37108	2 Position Selector, 1NO
34317	2 Position Selector, 1NC, 1NO (A-B)
34318	2 Position Selector, 2NO
34319	3 Position Selector, 2NC, (A-Both-B)
34320	3 Position Selector, 2NO (A-Off-B)
37109	2 Position Selector, 2NC
37110	3 Position Selector, 1NO, 1NC
34313	Mushroom, 30mm, Red, 1NC (HORN)
37122	Mushroom, 30mm, Red, 1NO
37123	Mushroom, 30mm, Red, 1NO, 1NC
37124	Mushroom, 30mm, Red, 2NC
37125	Mushroom, 30mm, Red, 2NO
34299	Alternative, 1NO
34300	Alternative, 1NC, 1NO
37126	Alternative, 2NO
34301	1NO
34302	Toggle, 1NC, 1NO
37127	Toggle, 1NO, 1NC
34314B	Variable Position Resistor (1K)
34314D	Variable Position Resistor (2K)
34314	Variable Position Resistor (5K)
34314C	Variable Position Resistor (10K)
34304	Blind Rubber Gasket with metal plate

# www.conductix.us

## USA / LATIN AMERICA

10102 F Street  
Omaha, NE 68127

Customer Support  
Phone +1-800-521-4888

Phone +1-402-339-9300  
Fax +1-402-339-9627

info.us@conductix.com  
latinamerica@conductix.com

## CANADA

1435 Norjohn Court  
Unit 5  
Burlington, ON L7L 0E6

Customer Support  
Phone +1-800-667-2487

info.ca@conductix.com

## MÉXICO

Calle Treviño 983-C  
Zona Centro  
Apodaca, NL México 66600

Customer Support  
Phone (+52 81) 1090 9519  
(+52 81) 1090 9025  
(+52 81) 1090 9013

Fax (+52 81) 1090 9014

info.mx@conductix.com

## BRAZIL

Rua Dois, 493  
Itu, São Paulo, Brasil  
CEP: 13312-820

Customer Support  
Phone (+55 11) 4813 7330

Fax (+55 11) 4813 7330

info.br@conductix.com

Contact us for our Global Sales Offices

